

INSTALLATION INSTRUCTIONS

Description:	Tachometer with System Monitor	Part Number: 990C0-80001/80101
Applications:	Suzuki Marine Boats	Installation Time: 1 HRS
NOTE:	Mounts in standard 3 3/8" hole.	Weight: 1 lbs

Contents

Ref.	Part Number	Description	QTY
1.	990C0-80001/80101	Tachometer w/ System Monitor	1
2.	BC0149	Mounting Bracket	1
3.	Mounting Hardware		1

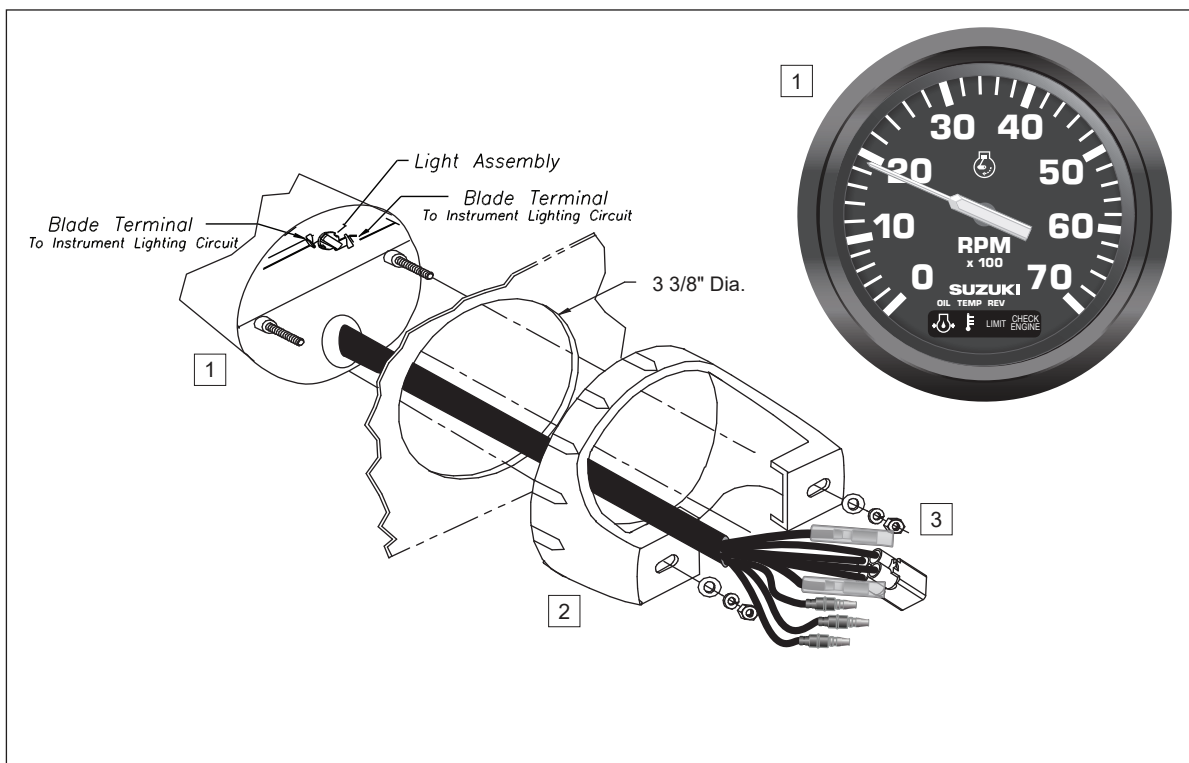

Tools Required

Ref.	Tools Description
1.	5/16" Nut Driver
2.	Suzuki Terminal Kit 09900-28701



Important

- ⚠ WARNING**
- ⚠ CAUTION**
- NOTE**

Please read this manual and follow its instructions carefully. To emphasize special information, the symbol **⚠** and the words **WARNING**, **CAUTION** and **NOTE** have special meanings. Pay special attention to the messages highlighted by these signal words:
NOTE: Indicates special information to make maintenance easier or instructions clear.

⚠ WARNING
 Indicates potential hazard that could result in death or injury.

⚠ CAUTION
 Indicates potential hazard that could result in vehicle damage.



CAUTION

- Disconnect battery during installation.
- Tighten nuts on backclamp only slightly more than you can tighten with your fingers. Six inch-pounds of torque is sufficient. Over tightening may result in damage to the instrument and may void your warranty.
- Gasket cement or other adhesive is not required to secure tubing to fittings.

Installation

1. Location: The tachometer should be located least 18" from a magnetic compass. Some interference (erratic operation) may be noticed on the tachometer during radio transmissions. This will neither damage the tachometer nor affect accuracy when not transmitting.

2. It is recommended that you use the included color coded wire extension leads.

3. Cut a 3-3/8" dia hole in the dash and mount the tachometer with the backclamp supplied.

4. Connect the Grey wire to the Harness connector marked (Ignition).

5. Connect the Yellow wire to the Harness connector marked (signal).

6. Connect the Black wire to the Harness connector marked (ground).

** (WHEN A STANDARD SIDE MOUNT REMOTE CONTROL IS USED, THE YELLOW TACH SIGNAL, SWITCHED POWER GRAY AND BLACK GROUND WIRES CAN BE FOUND AT THE CONTROL BOX.)

7. Connect the MONITOR BY ALIGNING the keys on the gauge's wire harness plug with the engine MONITOR harness (#36682-92E00) instrument's receptacle. Push the plug in gently until the catches snap in place.

8. Connect the GREEN/ORANGE extension lead to the blade terminal adjacent to the twist-out light assembly to the positive "+" side of the instrument lighting circuit and the bullet end to the boat lighting circuit. No separate ground is required for the lighting.

9. Reconnect the battery.

Mounting Hardware Kit



A		x 2
B		x 2
C		x 2

Figure 1



NOTE: To change light bulb, twist black socket assembly one-eighth turn counterclockwise until it pops out. Bulb pulls straight out of assembly. It is a GE No. 194 instrument lamp.

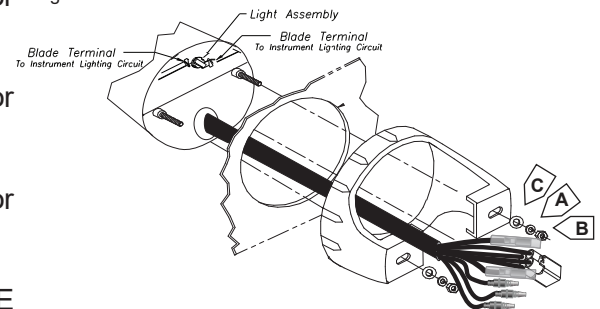

Harness Diagram

HN0415 rev A ecr 5609 8/05

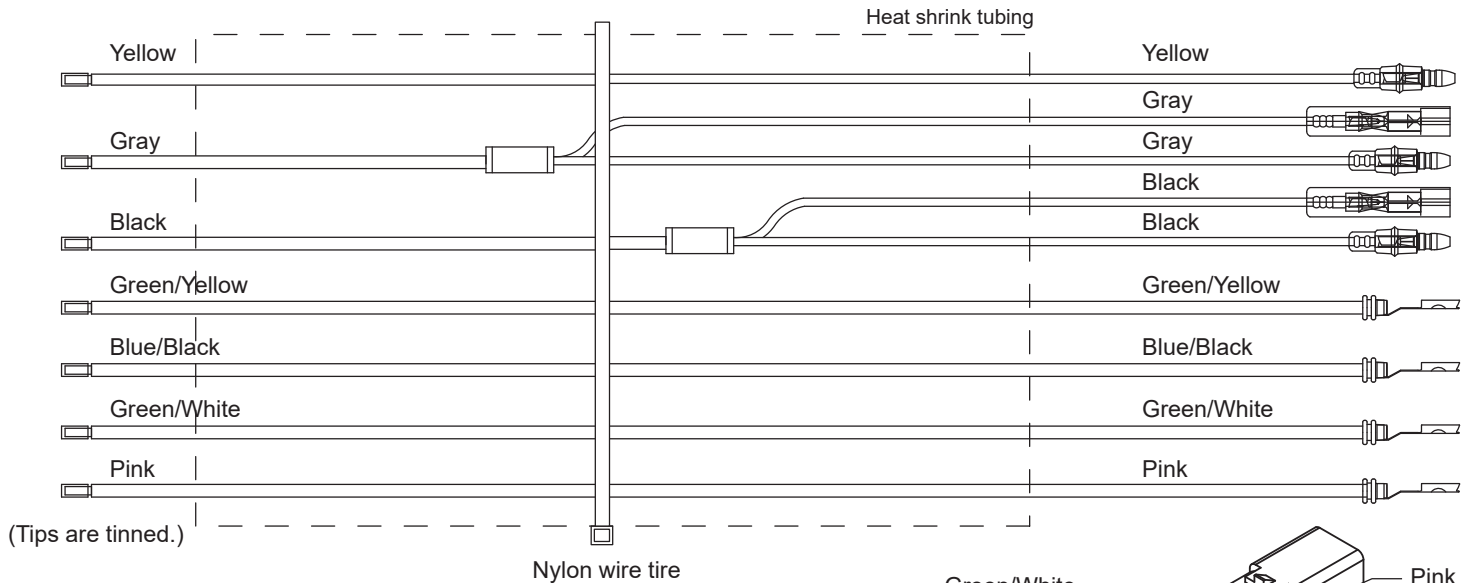
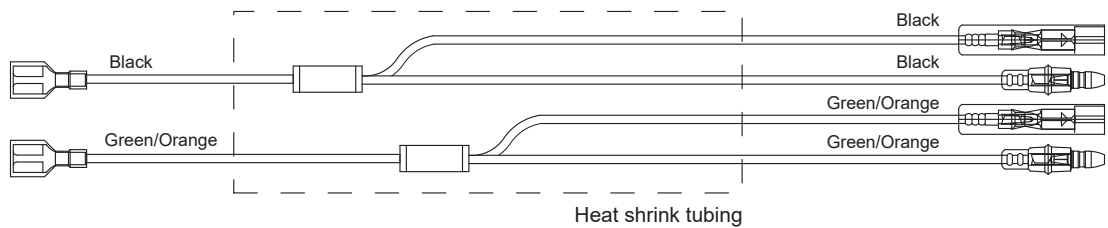

HN0408 rev B ecr 5609 8/05

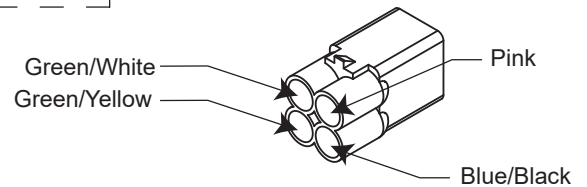

Trouble Shooting

Trouble	Inspection	Diagnosis	Action
Gauge Sticks	A. Backclamp may be too tight.	1. Slightly loosen nuts holding backclamp. Check operation.	1. If gauge works and is not loose in panel continue using gauge. 2. If gauge continues to stick, replace gauge.
Gauge Inoperative	A. Is power applied to gauge?	1. Switch the instrument power supply switch on and off. As power is supplied the pointer should jump slightly.	1. Check wires to check they were installed on the correct terminals and power is actually supplied to gauge. 2. If pointer jumps (indicating power supplied), check for signal from engine. If signal exist replace tachometer.



Trouble Shooting

Trouble	Inspection	Diagnosis	Action
Gauge is Erratic	A. Inspect the connection between the wire and the ring connector.	1. Check for insulation that may have been pushed into connection.	1. Fix connection.
	B. Check for excessive electrical noise caused by an electrical appliance set to close to the gauge. i.e. a magnetic compass, a radio transmission.	1. Check wires by connecting one wire at a time to the Tach directly from the battery or the signal source on the engine.	1. Relocate offensive appliance. Please refer to installation instructions.
	C. A reading of Hi or Low may be the cause of alternator pole switch not selected correctly.	1. Check the switch on the back of the tachometer. Refer to chart below.	1. If the tachometer reads too high, then the switch is selected too low. 2. If the tachometer reads too low, then the switch is selected too high.

Outboard Tachometer Application Chart

Make/ Year	Model	# of Poles.
Suzuki through 2006 All Suzuki 4-strokes, DF40 and larger, will require a Tach/System Monitor or 2" System Monitor gauge to properly indicate any warning or diagnostic event.	Less than 55 HP - All 60 HP, 65 HP thru 1985 50 - 60 HP Cabrea	4
	DF 4 through 30 (4 stroke) 25 HP & 30 HP (1993 & later) 55 HP & 65 HP (1985 & later)	6
	75 HP & up (1985 & later) 75 HP and up (Cabrea) 115 HP and up (1988 & later) DF 40 through DF 250, DFV6 (4 stroke)	12