

Pocket Guide

# Viega MegaPress® Stainless Systems



Viega.

Connected in quality.

### Building on Tradition

Founded 120 years ago, Viega is a privately owned, international group of companies. In the United States, Canada, Mexico, and Latin America, Viega specializes in plumbing, heating, and pipe joining technologies. The values of Viega's founder, Franz-Anselm Viegener, are just as present today as they were when he started the company in 1899. Courage, passion, and innovative spirit are still the basics of Viega's foundation.



MegaPress 304 FKM ½" to 2" formerly MegaPress Stainless 304.  
 MegaPress 304 FKM 2½" to 4" formerly MegaPress Stainless 304 XL.  
 MegaPress 316 ½" to 2" formerly MegaPress Stainless 316.  
 MegaPress 316 2½" to 4" formerly MegaPress Stainless 316 XL.

### At Viega, safety is priority.

Safe, certain, and secure, Viega fittings are designed for peace of mind

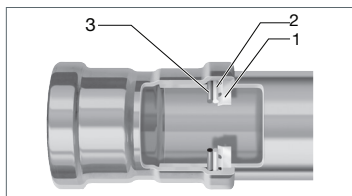

1. In MegaPress stainless fittings, the 420 stainless steel grip ring's teeth cut into the pipe and lock the fitting securely in place.

- For ½" to 2" fittings, a 304 stainless steel separator ring protects the sealing element from damage by creating a positive physical separation during installation. For 2½" to 4" fittings, a PBT (Polybutylene Terephthalate) separator ring protects the sealing element.
- The FKM sealing element in MegaPress 304 FKM fittings and the EPDM sealing element in MegaPress 316 fittings ensure water-tight or air-tight connections.

In all MegaPress stainless fittings, Viega's unique, patented Smart Connect technology helps installers ensure that they have pressed all connections.



White dot on a Viega MegaPress 304 FKM fitting indicates Smart Connect technology with an FKM sealing element. A green dot on a Viega MegaPress 316 fitting indicates Smart Connect technology with an EPDM sealing element. For a current list of applications, please visit [www.viega.us/applications](http://www.viega.us/applications).

<b>Introduction</b>	<b>4</b>
MegaPress Stainless Systems	4
<b>System Data</b>	<b>6</b>
Viega MegaPress 304 FKM Fitting Systems	6
Viega MegaPress 316 Fitting Systems	7
<b>Tech Data</b>	<b>8</b>
Viega MegaPress 304 FKM 3-Piece Ball Valve, Model 4175.8	8
Viega MegaPress 316 3-Piece Ball Valve, Model 5175.8	9
<b>Product Instructions</b>	<b>10</b>
Viega MegaPress Stainless ½" to 2" Fittings	10
Viega MegaPress Stainless 2½" to 4" Fittings	11
<b>Technical Information</b>	<b>12</b>
Approved Applications	12
Sealing Element Description	14
Minimum Clearance Between Two Viega Press Connections	15
Viega MegaPress Stainless Steel Pipe Marking Guide	16
No-Stop Couplings	17
Welding	17
General Installation Notes	18
Deflection	19
Tool Clearances	20
Pressing with Ring and Actuator in Tight Quarters	22
<b>Dimensional Documentation</b>	<b>23</b>
MegaPress Stainless ½" to 2"	23
MegaPress Stainless 2½" to 4"	29
<b>Frequently Asked Questions</b>	<b>35</b>
<b>Limited Warranty</b>	<b>36</b>
Viega Metal Systems for Industrial Applications	36
Viega Marine Applications	38



Viega products are designed to be installed by licensed and trained plumbing and mechanical professionals who are familiar with Viega products and their installation. **Installation by non-professionals may void Viega LLC's warranty.**



**DANGER!** Read and understand all instructions for installing Viega MegaPress stainless fittings. Failure to follow all instructions may result in extensive property damage, serious injury, or death.



This document is subject to updates. For the most current Viega technical literature please visit [www.viega.us](http://www.viega.us).

## MegaPress Stainless Systems

Viega MegaPress stainless systems can help reduce installation time up to 90 percent compared to traditional methods of pipe joining. Soldering and welding can be messy and time consuming, and connections are not always reliable. With Viega press technology, installers can make consistent, secure press connections in a matter of seconds, without flame or heavy equipment.

The fittings require no soldering or welding and are installed with electro-hydraulic press tools (battery-powered or corded press tools).

Viega MegaPress stainless fittings can be customized for a wide variety of applications in industrial, commercial, or residential projects.

## Fire Protection You Can Count On

With FM and UL certification for MegaPress ½" to 2" sizes, with 2½" to 4" sizes soon to be added to the listing, Viega is introducing the latest press system for the fire protection market. Viega MegaPress 304 FKM and 316 fittings can be used in prefabricated assemblies, producing a straight, clean installation.

Backed by a written, limited warranty and approved for NFPA 13, 13D, and 13R fire sprinkler systems, MegaPress stainless can be installed in industrial applications or commercial projects like hotels and dorms. With Viega's patented cold-press technology, installations in attics and tight corners are safer than with traditional joining methods. Installers don't need to carry heavy equipment or bother with metal shavings or cutting oils.

## Smart Connect Technology – Security Under Pressure

Locating unpressed connections is an important step in the pressure testing process. Viega MegaPress stainless includes Smart Connect technology, providing quick and easy identification of unpressed connections during a pressure test.

Smart Connect technology is an integral part of the design of the fitting, providing a path for liquids and/or gases from inside the system past the sealing element of an unpressed connection. When pressed according to our Product Instructions, the fluid path is altered, creating a leak-proof, reliable connection.

Unpressed connections are located by pressurizing the system with air or water. When testing with water the proper pressure range is 15 to 85 psi. Pressure testing with air can be dangerous at high pressures. When testing with compressed air the proper pressure range is 1/2 to 45 psi. Following a successful Smart Connect test, the system may be pressure tested up to 600 psi maximum for water and 200 psi maximum for air if required by local code requirements.



**1** Identify an unpressed connection during pressure testing when water flows past the sealing element.

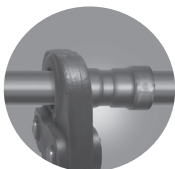

**2** Upon identification, use the press tool to press the fitting, making a secure, leak-proof connection.

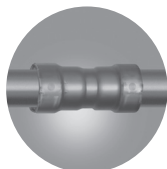

**3** Viega MegaPress stainless connections are fast, flameless, and reliable.

## Viega MegaPress 304 FKM Fitting Systems

Viega MegaPress 304 FKM fittings are designed to be used with off-the-shelf Schedule 10 to Schedule 40 stainless steel pipe to form a complete press system that is ideal for industrial applications. A Viega MegaPress 304 FKM system can stand up to harsh environments while transporting process water, diesel fuel, lube oil, ammonia, low pressure steam, or any number of other essential fluids or gases.

Viega MegaPress 304 FKM fittings in sizes from ½" to 4" are offered in configurations including: elbows, couplings, reducers, tees, reducing tees, threaded adapters, unions, caps, and flanges.

### Components

- Alloy: 304 stainless steel
- FKM sealing element
- 420 stainless steel grip ring
- 304 stainless steel separator ring for ½" to 2" fittings
- PBT separator ring for 2½" to 4" fittings

### Operating Parameters

- Operating Pressure: 200 psi maximum
- Test Pressure: 600 psi maximum
- Operating Temperatures: 14°F to 284°F (with temperature spikes up to 356°F)

### Listings and Certificates

- ABS type approval
- ASME B31.1, B31.3, B31.9
- BV (Bureau Veritas)
- CRN 13492.5 A/B/C
- DNV-GL
- FM Class 1920
- IAPMO PS-117
- ICC-ES LC1002
- Lloyds Register
- NFPA 13, 13D, 13R
- UL/ANSI 213
- ULC/ANSI ORD-C213

### Compliant with:

- ASME B31
- ASTM A312
- ASTM A554
- IAPMO Uniform Mechanical Code (UMC)
- ICC International Mechanical Code (IMC)
- ICC International Residential Code (IRC)
- National Building Code of Canada (NBCC)
- National Plumbing Code of Canada (NPCC)

### Approved Applications

- Process water (non-potable)
- Low pressure steam
- Industrial gases
- Compressed air (no oil)
- Lube oil
- Caustic solutions
- Acid solutions
- Vacuum

For more specific information on applications for MegaPress 304 FKM, contact Viega Technical Services at 1-800-976-9819.

Viega MegaPress 304 FKM systems are approved for underground use. When installed underground, Viega MegaPress 304 FKM should have proper corrosion protection in accordance with local and national codes.

### Recommended Tools

- Standard size press tool (minimum hydraulic ram output of 7200 lbs.)
- #56013 MegaPress jaw/ring kit (½" to 2")
- #26200 MegaPress XL PressBooster with 2½" press ring
- #26201 MegaPress XL 3" and 4" press ring kit



The use of the system for applications other than those listed or outside of these parameters must be approved by the Viega Technical Services Department.

## Viega MegaPress 316 Fitting Systems

Viega MegaPress 316 fittings are designed to be used with standard IPS ASTM A312 Schedule 10 to Schedule 40 stainless steel pipe and are ideal for industrial applications. A Viega MegaPress 316 system can stand up to harsh environments while transporting process water, potable water, ammonia, low pressure steam, or any number of other essential fluids or gases.

Viega MegaPress 316 fittings in sizes from ½" to 4" are offered in configurations including: elbows, couplings, reducers, tees, reducing tees, threaded adapters, unions, caps, and flanges.

### Components

- Alloy: 316 stainless steel
- EPDM sealing element
- 420 stainless steel grip ring
- 304 stainless steel separator ring for ½" to 2" fittings
- PBT separator ring for 2½" to 4" fittings

### Operating Parameters

- Operating Pressure: 200 psi maximum
- Test Pressure: 600 psi maximum
- Operating Temperature: 0°F to 250°F

### Listings and Certificates

- ABS type approval
- ASME B31.1, B31.3, B31.9
- BV (Bureau Veritas)
- CRN 13492.5 A/B/C
- DNV-GL
- FM Class 1920
- IAPMO PS-117
- ICC-ES LC1002
- Lloyds Register
- NFPA 13, 13D, 13R
- NSF/ANSI 61
- NSF/ANSI 372
- UL/ANSI 213
- ULC/ANSI ORD-C213

### Compliant with:

- ASME B31
- ASTM A312
- ASTM A554
- IAPMO California Plumbing Code (CPC)
- IAPMO National Standard Plumbing Code (NSPC)
- IAPMO Uniform Mechanical Code (UMC)
- IAPMO Uniform Plumbing Code (UPC)
- ICC International Mechanical Code (IMC)
- ICC International Plumbing Code (IPC)
- ICC International Residential Code (IRC)
- National Building Code of Canada (NBCC)
- National Plumbing Code of Canada (NPCC)

### Approved Applications:

- Process water (non-potable)
- Low pressure steam
- Industrial gases
- Potable water
- Caustic solutions
- Acid solutions
- Vacuum

For more specific information on applications for MegaPress 316, contact Viega Technical Services at 1-800-976-9819.

Viega MegaPress 316 systems are approved for underground use. When installed underground, Viega MegaPress 316 should have proper corrosion protection in accordance with local and national codes.

### Recommended Tools

- Standard size press tool (minimum hydraulic ram output of 7200 lbs.)
- #56013 MegaPress jaw/ring kit (½" to 2")
- #26200 MegaPress XL PressBooster with 2½" press ring
- #26201 MegaPress XL 3" and 4" press ring kit



It is the responsibility of the installer or any other parties to adhere to all applicable local rules and regulations governing the nature of the installation.

## Viega MegaPress 304 FKM 3-Piece Ball Valve, Model 4175.8

The MegaPress 304 FKM 3-piece stainless steel ball valve is equipped with a full port, 316 stainless steel 3-piece body, and 304 stainless steel press ends. The ball valve features an FKM sealing element, a 420 stainless grip ring, a 304 stainless separator ring, PTFE stem seals, a locking metal handle, and Viega's Smart Connect technology for easy identification of unpressed connections during pressure testing.

### Features

- 316 stainless steel ball
- Blowout-proof 316 stainless steel stem
- 304 stainless steel locking handle
- Adjustable packing nut
- Reinforced PTFE seats
- Smart Connect technology
- ISO 5211 mounting pad

### Ratings

- Max Operating Pressure: 250 CWP
- Operating Temperatures: 14°F to 284°F (with temperature spikes up to 356°F)

### Approvals

- Conforms to MSS SP-110
- ASME B31
- IAPMO Z1157

## Viega MegaPress 304 FKM 3-Piece Stainless Steel Ball Valve - Model 4175.8

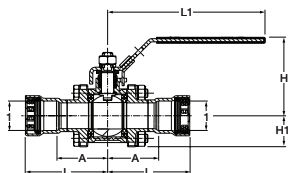

Part No.	Size (in)	A (in)	L (in)	L1 (in)	H (in)	H1 (in)
	1					
86500	½	1.72	2.80	5.88	2.85	1.04
86505	¾	1.91	3.06	5.88	2.93	1.16
86510	1	2.19	3.54	7.54	3.33	1.40
86515	1¼	2.50	4.31	7.54	3.57	1.57
86520	1½	2.92	4.79	7.54	3.89	1.83
86525	2	3.09	5.07	7.54	3.89	1.83

Valve Size (in)	Valve Body Bolt & Nut Size		Bolt Torque +/- 5		Valve Stem Nut Size	Stem Nut	
			ft/lbs	(Nm)		ft/lbs	(Nm)
½	M8 x 55	M8	7.5	(10)	AF 16 mm	7.5	10
¾	M8 x 65	M8	15	(20)	AF 18 mm	11	15
1	M10 x 75	M10	15	(20)	AF 21 mm	11	15
1¼	M10 x 90	M10	22.5	(30)	AF 22 mm	18.5	25
1½	M10 x 100	M10	22.5	(30)	AF 24 mm	18.5	25
2	M10 x 100	M10	22.5	(30)	AF 24 mm	18.5	25



## Viega MegaPress 316 3-Piece Ball Valve, Model 5175.8

The MegaPress 316 3-piece stainless steel ball valve is equipped with a full port, 316 stainless steel 3-piece body, and stainless steel press ends. The ball valve features an EPDM sealing element, a 420 stainless steel grip ring, a 304 stainless separator ring, PTFE stem seals, a locking metal handle, and Viega's Smart Connect® technology for easy identification of unpressed connections during pressure testing.

### Features

- 316 stainless steel ball
- Blowout-proof 316 stainless steel stem
- 304 stainless steel locking handle
- Adjustable packing nut
- Reinforced PTFE seats
- Smart Connect technology
- ISO 5211 mounting pad

### Ratings

- Max Operating Pressure: 250 CWP
- Operating Temperatures: 0°F to 250°F

### Approvals

- Conforms to MSS SP-110
- ASME B31
- IAPMO Z1157
- NSF 61-372

## Viega MegaPress 316 3-Piece Stainless Steel Ball Valve - Model 5175.8

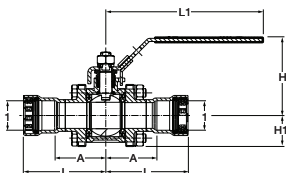

Part No.	Size (in)	A (in)	L (in)	L1 (in)	H (in)	H1 (in)
	1					
86530	½	1.72	2.80	5.88	2.85	1.04
86535	¾	1.91	3.06	5.88	2.93	1.16
86540	1	2.19	3.54	7.54	3.33	1.40
86545	1¼	2.50	4.31	7.54	3.57	1.57
86550	1½	2.92	4.79	7.54	3.89	1.83
86555	2	3.09	5.07	7.54	3.89	1.83

Valve Size (in)	Valve Body Bolt & Nut Size		Bolt Torque +/- 5		Valve Stem Nut Size	Stem Nut	
			ft/lbs	(Nm)		ft/lbs	(Nm)
½	M8 x 55	M8	7.5	(10)	AF 16 mm	7.5	10
¾	M8 x 65	M8	15	(20)	AF 18 mm	11	15
1	M10 x 75	M10	15	(20)	AF 21 mm	11	15
1¼	M10 x 90	M10	22.5	(30)	AF 22 mm	18.5	25
1½	M10 x 100	M10	22.5	(30)	AF 24 mm	18.5	25
2	M10 x 100	M10	22.5	(30)	AF 24 mm	18.5	25

## Viega MegaPress Stainless 1/2" to 2" Fittings

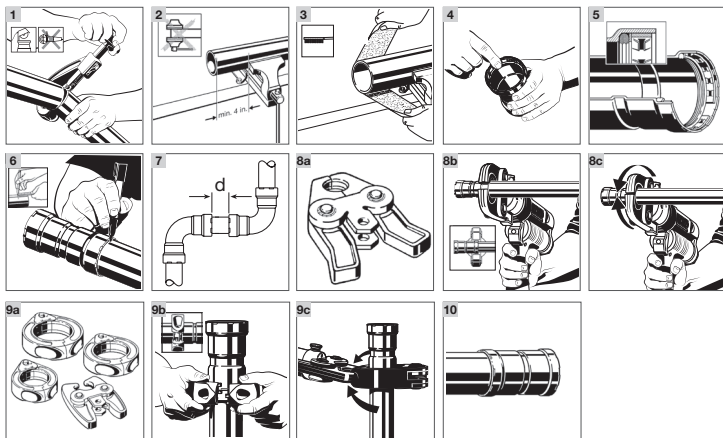

- 1** Cut piping at right angles using displacement-type cutter.
- 2** Keep end of piping a minimum of 4" away from the contact area of the vise to prevent possible damage to the piping.
- 3** Deburr inside and outside of the pipe and prep to proper insertion depth using a preparation tool or fine-grit sandpaper.
- 4** Check seal and grip ring for correct fit. Do not use oils or lubricants.
- 5** Illustration demonstrates proper fit of grip ring, separation ring, and sealing element.
- 6** Mark proper insertion depth. Improper insertion depth may result in an improper seal. The depth marking must be visible on the completed assembly.

**Minimum Insertion Depth for MegaPress Stainless**

Pipe Size	1/2"	3/4"	1"	1 1/4"	1 1/2"	2"
Insertion Depth	1 1/16"	1 3/16"	1 3/8"	1 9/16"	1 7/8"	2"

- 7** Refer to chart on page 15 for minimum distance between fittings. To ensure a correct press, a minimum distance between press fittings must be maintained. Failure to provide this distance may result in an improper seal.

- 8a** Viega MegaPress stainless 1/2" to 1" fitting connections must be performed with MegaPress jaws.



### WARNING!

Keep extremities and foreign objects away from press tool during pressing operation to prevent injury or incomplete press.

- 8b** Open the MegaPress jaw and place at right angles on the fitting. Visually check insertion depth using mark on piping.
- 8c** Start pressing process and hold the trigger until the jaw has engaged the fitting.
- 9a** MegaPress stainless 1 1/4" to 2" fitting connections must be performed with MegaPress rings and V2 Actuator.
- 9b** Open MegaPress ring and place at right angles on the fitting. MegaPress ring must be engaged on the fitting bead. Check insertion depth.
- 9c** Place V2 Actuator onto MegaPress ring and start pressing process. Hold the trigger until the Actuator has engaged the MegaPress ring.
- 10** Remove MegaPress jaw from fitting or release V2 Actuator from MegaPress ring and then remove MegaPress ring from the fitting. Remove control label to indicate press has been completed.

**Viega MegaPress Stainless 2½" to 4" Fittings**

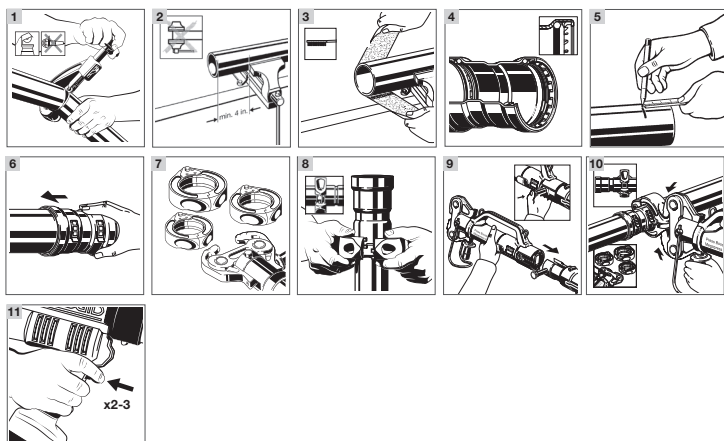

- 1** Cut piping at right angles using displacement-type cutter.
- 2** Keep end of piping a minimum of 4" away from the contact area of the vise to prevent damage to the piping in the press area.
- 3** Deburr inside and outside of piping and prep to proper insertion depth using a preparation tool or fine-grit sandpaper.
- 4** Illustration demonstrates proper fit of grip ring, separation ring, and sealing element.
- 5** Mark the proper insertion depth on the outside of the pipe (see table below). Improper insertion depth may result in an improper seal. The depth marking should be visible on the completed assembly.

**Minimum Insertion Depth for MegaPress Stainless**

Pipe Size	2½"	3"	4"
Insertion Depth	1 13/16"	2 5/16"	3 1/8"

- 6** While turning slightly, slide press fitting onto the pipe to the marked insertion depth. End of pipe must contact stop.

- 7** Viega MegaPress stainless 2½" to 4" fitting connections must be made using MegaPress XL rings and a PressBooster/Z3 Actuator.

**WARNING!**  
 Keep extremities and foreign objects away from press tool during pressing operation to prevent injury or incomplete press.

- 8** Open MegaPress ring and place at right angles on the fitting. MegaPress ring must be engaged on the fitting bead. Check insertion depth.
- 9** Remove the retaining bolt of the press machine. Slide the PressBooster in via the press jaw fixture.
- 10** Place PressBooster/Z3 Actuator onto MegaPress XL rings and start pressing process. Hold the trigger until the Actuator has engaged the MegaPress ring.
- 11** The PressBooster requires two presses of the trigger to execute a complete press. A third press may be needed to initiate a release cycle to reset the rollers back to the original position.

## Approved Applications

Types of Service	System Operating Conditions			MegaPress 304 FKM	MegaPress 316
	Comments	Pressure	Temperature	FKM	EPDM
<b>Fluids/Water</b>					
Hot and Cold Potable Water		200 psi	32°F to 250°F		√
Rainwater/ Gray Water		200 psi	Ambient		√
Fire Sprinkler	NFPA 13, 13D, 13R	175 psi	Ambient	√	
Chilled Water	Ethylene Glycol / Propylene Glycol	200 psi	0°F to 250°F	√	√
Hydronic Heating	Ethylene Glycol / Propylene Glycol	200 psi	0°F to 250°F	√	√
Cooling Water	Up to 50% Ethylene Glycol or Propylene Glycol Solution	200 psi	0°F to 250°F	√	√
Deionized Water		200 psi	Max 230°F		√
Low Pressure Steam		Max 15 psi	Max 250°F	√	√
Isopropyl Alcohol		200 psi	Ambient	√	√
Latex Paint		200 psi	32°F to 250°F		√
Methyl Ethyl Ketone		200 psi	Max 100°F		√
Nitric Acid		200 psi	Ambient	√	√
Phosphoric Acid		200 psi	Ambient		√
Paraffin Wax		200 psi	Max 100°F	√	
<b>Fuel, Oil, and Lubricant</b>					
Heating Fuel Oil		125 psi	Max 100°F	√	
Diesel Fuel		125 psi	Max 100°F	√	
Ethanol	Pure Grain Alcohol	200 psi	Ambient		√
Kerosene		125 psi	Max 68°F	√	
Lube Oil	Petroleum Based	200 psi	Max 150°F	√	
Mineral Oil		200 psi	Ambient	√	

Types of Service	System Operating Conditions			MegaPress 304 FKM	MegaPress 316
	Comments	Pressure	Temperature	FKM	EPDM
<b>Gases</b>					
Compressed Air	Less than 25mg/ m <sup>3</sup> Oil Content	200 psi	Max 140°F	√	√
Compressed Air	More than 25mg/ m <sup>3</sup> Oil Content	200 psi	Max 140°F	√	
Oxygen - O <sub>2</sub> (nonmedical)	Keep Oil and Fat Free/Non-Liquid O <sub>2</sub>	140 psi	Max 140°F	√	√
Nitrogen - N <sub>2</sub>		200 psi	Max 140°F	√	√
Ammonia	Anhydrous	200 psi	Max 120°F		√
Acetylene		20 psi	Ambient	√	√
Argon	Welding Use	200 psi	Max 140°F	√	√
Hydrogen - H <sub>2</sub>		125 psi	Max 140°F		√
Vacuum		29.2" of Hg	Max 160°F	√	√
It is recommended that all systems be clearly labeled with the fluid or gas being conveyed. For further information please consult Viega Technical Services.					
All Viega systems must be used with the manufacturer's recommended sealing element. Contact your local Viega representative or Viega Technical Services for application temperature, pressure, and concentration limits.					

## Sealing Element Description

### FKM Sealing Element

MegaPress 304 FKM press fittings are manufactured with an FKM sealing element installed at the factory. FKM is well known for its excellent resistance to petroleum products and solvents as well as exceptional high-temperature performance, which make it ideal for seals and gaskets in solar, district heating, low pressure steam, and compressed air systems.

**Definition:** FKM

Fluoroelastomer, dull black in color

**Maximum Pressure:** 200 psi

**Operating Temperature:** 14°F to 284°F  
(with temperature spikes up to 356°F)

The FKM sealing element is a special-purpose elastomer typically installed where higher temperatures are required. It possesses excellent resistance to aging, ozone, sunlight, weathering, environmental influences, and oils and petroleum-based additives.

### EPDM Sealing Element

MegaPress 316 press fittings are manufactured with an EPDM sealing element installed at the factory. The EPDM sealing element is used mainly for potable water, hydronic heating, low pressure steam, fire sprinkler, and compressed air installations.

**Definition:** EPDM

Ethylene-Propylene-Diene-Monomer, gloss black in color

**Maximum Pressure:** 200 psi

**Operating Temperature:** 0°F to 250°F

The EPDM sealing element is a synthetically manufactured and peroxidically cross-linked, general-purpose elastomer with a wide range of applications. It is resistant to aging, ozone, sunlight, weathering, environmental influences, chemicals, and most alkaline solutions.

The EPDM sealing element is used mainly in the applications of hydronic heating, chilled water, and fire sprinkler installations. It is not resistant to hydrocarbon solvent solutions, oils, chlorinated hydrocarbons, turpentine, and gasoline.

## Minimum Clearance Between Two Viega Press Connections

Viega MegaPress Stainless		
Tubing Diameter (in)	Minimum Clearance (in)	Minimum Clearance (mm)
1/2	1/4	5
3/4	1/4	5
1	1/4	5
1 1/4	1/2	10
1 1/2	1/2	10
2	1/2	10
2 1/2	1/2	10
3	1/2	10
4	1/2	10

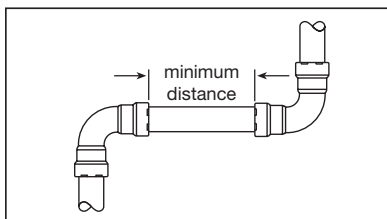

## Viega MegaPress Stainless Steel Pipe Marking Guide

Guide to the ANSI A13.1 Standard for the Identification of Pipes

Viega MegaPress stainless ½" to 4" fittings are compatible with ASTM A312 stainless steel pipe. All Viega MegaPress stainless piping systems should be continuously marked in accordance with ANSI A13.1 or as required by the local authority having jurisdiction.

Usage	Material Properties	Type of Application (typical)	Color Scheme
Hazardous Materials	<ul style="list-style-type: none"> <li>■ Flammable or Explosive</li> <li>■ Chemically Active or Toxic</li> <li>■ Radioactive</li> <li>■ Extreme Temperature/Pressure</li> </ul>	<ul style="list-style-type: none"> <li>■ Process Piping</li> <li>■ High-Pressure Steam</li> <li>■ Acids/Corrosives</li> </ul>	<b>YELLOW ON BLACK</b>
Low Hazard Materials (Liquid)	<ul style="list-style-type: none"> <li>■ Liquid</li> <li>■ Liquid Admixture</li> </ul>	<ul style="list-style-type: none"> <li>■ Cooling Water</li> <li>■ Grey Water</li> <li>■ Chilled Water</li> </ul>	<b>WHITE ON GREEN</b>
Low Hazard Materials (Gas)	<ul style="list-style-type: none"> <li>■ Gas</li> <li>■ Gas Admixture</li> </ul>	<ul style="list-style-type: none"> <li>■ Compression Air</li> <li>■ Nitrogen (N2)</li> <li>■ Argon (Ar)</li> </ul>	<b>WHITE ON BLUE</b>
Fire Suppression	<ul style="list-style-type: none"> <li>■ Liquid</li> <li>■ Gas</li> <li>■ Foam</li> </ul>	<ul style="list-style-type: none"> <li>■ Sprinklers (Wet/Dry)</li> <li>■ CO2</li> <li>■ Foam (AFFF)</li> </ul>	<b>WHITE ON RED</b>

Pipe O.D. Including Covering		Minimum Length of Label Field Color		Minimum Height of Letters	
¾" to 1¼"	19 mm to 32 mm	8"	203 mm	½"	13 mm
1½" to 2"	38 mm to 51 mm	8"	203 mm	¾"	19 mm
2½" to 4"	64 mm to 108 mm	12"	305 mm	1¼"	32 mm

### Marker Placement

- At all changes in direction
- At both sides of any penetrations (valves, flanges, tees, etc.)
- At frequent intervals on straight run (50 feet is typical)
- Locate pipe markers so they are readily visible
- Provide arrows indicating direction of flow

**Note:** This guide is for general information purposes only. Pipe markings shall be in accordance with local code requirements.



## No-Stop Couplings

No-stop couplings and extended no-stop couplings are often used to conduct repairs. Without a stop, these couplings can slide completely onto a pipe and allow a connection to be made in tighter spaces. Unlike fittings with an integrated stop that have a minimum insertion depth, no-stop couplings have minimum and maximum allowable insertion depths. The minimum and the maximum insertion depths should be marked and a line should connect the two marks. Drawing a line between the minimum and maximum insertion marks distinguishes a good connection on a no-stop coupling from a bad connection on a coupling with a stop.

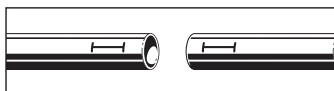

**Viega MegaPress Stainless No-Stop Couplings**

Pipe Diameter	Minimum Insertion		Maximum Insertion	
	in	mm	in	mm
½	1 <sup>1</sup> / <sub>16</sub>	27	1 <sup>5</sup> / <sub>16</sub>	41
¾	1 <sup>3</sup> / <sub>16</sub>	29	1 <sup>9</sup> / <sub>16</sub>	46
1	1 <sup>3</sup> / <sub>8</sub>	34	1 <sup>5</sup> / <sub>8</sub>	49
1¼	1 <sup>9</sup> / <sub>16</sub>	46	2½	63
1½	1 <sup>7</sup> / <sub>8</sub>	48	2¾	70
2	2	50	2¾	70
2½	1 <sup>9</sup> / <sub>16</sub>	46	3 <sup>1</sup> / <sub>8</sub>	79
3	2 <sup>5</sup> / <sub>16</sub>	59	3 <sup>11</sup> / <sub>16</sub>	93
4	3 <sup>1</sup> / <sub>8</sub>	80	4 <sup>3</sup> / <sub>8</sub>	120

## Welding

The following requirements must be considered when welding in the same vicinity as Viega MegaPress stainless fittings.

### Welding Adjacent to a Press Fitting

To prevent damage to the sealing element, maintain proper welding distances from the fitting. If welding adjacent to the connection, weld a minimum of four inches away.

### Welding In Line with a Press Fitting

To prevent damage to the sealing element, maintain proper welding distances from the fitting. If welding in line with the connection, weld a minimum of three feet away from the connection to protect the sealing element.

### Welding Requirements

The installer should take precautions to keep the MegaPress stainless connection cool:

- Wrap the connection with a cold, wet rag.
- Protect the connection with a weld blanket.
- Prefabricate solder connections/welded fittings prior to installing the press fitting. (Ensure pipe has cooled before installing the press fitting.)
- Apply heat sink gel or spray or spot freezing.

## General Installation Notes

### Expansion

Thermal expansion in installed systems generates stress on pipes and appliance connectors. Compensation must be allowed for expansion and contraction that may occur within the piping system. Expansion joints or mechanical expansion compensators may be used to alleviate these stresses.

### Electrical Bonding

When properly installed, MegaPress stainless fittings comply with Section 1211.15 Electrical Bonding and Grounding of the Uniform Plumbing Code.

The mechanical press provides continuous metal-to-metal contact between fitting and pipe. The press ensures the continuity of the bonding through this contact.

### Exposure to Freezing Temperatures

Viega MegaPress 316 systems with EPDM sealing elements can be installed in ambient temperatures down to 0°F. The FKM sealing element available with Viega MegaPress 304 FKM fittings can be installed in ambient temperatures down to 14°F. When the contents could freeze, piping must be protected per acceptable engineering practices, codes, and as required by local code.

### Underground Installations

Viega MegaPress stainless fitting systems and stainless pipe are approved for underground installations. However, installations must meet all state and local codes, including those for underground. Proper authorization must be obtained prior to installation from the Authority Having Jurisdiction.

### Corrosion Protection

Viega MegaPress stainless fittings exposed to corrosive action, such as soil conditions or moisture, must be protected in an approved manner in accordance with

NACE Standard RP0169-2002 Section 5, 2009 UPC Chapter 6 Section 609.3.1, 2009 UMC Chapter 13 Section 1312.1.3, and in a manner satisfactory to local code requirements. Care should be taken to select hangers of suitable material that is galvanically compatible with the piping system. In addition, systems should be properly sized to minimize the risk of erosion corrosion resulting from excessive velocities.

### Pressure Surges

- Pressure surges or transients from fast-acting valves, pump surges, and other sources that result in water hammer may cause damage to many system components, including press fittings.
- When fast-acting valves and/or pumps are incorporated into a system, the designer and installer should isolate press fittings from sharp pressure surges.

### Transition Fittings – Threaded

Viega MegaPress stainless systems can be joined with off-the-shelf threaded fittings made of non-ferrous metals. In this regard:

- The threaded connection is made first.
- The press connection is made second.

This process avoids unnecessary torsion on the press fitting.

### Transition Fittings – Flange

When using Viega flanges, bolt the flange end in place prior to pressing the fitting to the pipe.

### Rotating a Pressed Fitting

Once a MegaPress stainless fitting has been pressed, it can be rotated (not by hand), but once rotated more than five degrees, the fitting should be re-pressed to restore resistance to rotational movement. If the fitting is re-pressed, care should be taken to align the flat sides on the jaw with those on the fitting.

## Deflection

The pressing process can cause deflection (angular misalignment) to occur. When pressing Viega MegaPress stainless fittings in a system, the deformation of the fitting is constant. This allows for a consistent leak-free joint every time and is a result of the pressing technique.

Deflection occurs in the same way for every fitting. The fitting being pressed will move in the direction of the jaw or ring opening.

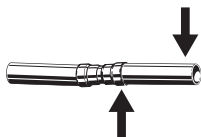

- Since the fitting will deflect toward the opening of the jaw or ring, the pipe end will deflect in the opposite direction.
- By counteracting the fitting movement, one can minimize the deflection of the fitting and ultimately the pipe.
- When using strut and clamps, deflection is minimized and nearly eliminated depending on clamp spacing.

### Controlling Deflection

Deflection while pressing can be minimized by utilizing the following installation practices.

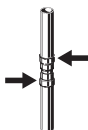

#### Alternate Sides for Presses

- Press one end of fitting.
- Make second press on other end of fitting from the opposite side.

#### Push-Pull Method

- Rings = Push on press tool.
  - Jaws = Pull on press tool.
- The press tool can be feathered using the trigger as needed to apply pulling or pushing force to control deflection.

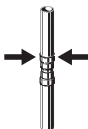
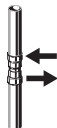

#### Re-Press

- Press the fitting, once on each side (that is, re-press the fitting a second time on the opposite side).
- Pressing the same connection from the opposite side will usually straighten misalignment between the pipe and fitting.

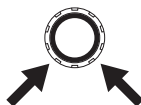

- When pressing overhead piping, it may be inconvenient to alternate sides for each press.
- The natural weight of the piping plus pressing on opposite sides at a 45-degree angle should adequately eliminate deflection.
- This technique can also be used for any horizontal piping and when working above the piping.

## Tool Clearances

Minimum distances should be taken into consideration during planning in order to avoid space constraints during installation.

Ensure that the space required for system pressing tools is available if Viega MegaPress stainless fittings will be installed immediately upstream or downstream from wall or floor penetrations.

### MegaPress Distance Requirements for Press Jaws Between Pipes and Walls

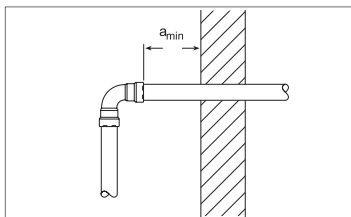

Pipe Diameter	Minimum space requirement, $a_{min}$ for press tools
	RIDGID RP 330-B, 330-C, and 340-B Press Tool
1/2" to 1"	1 1/8"
1 1/4" to 2"	3/4"
2 1/2" to 4"	3/4"

### MegaPress Standard Jaws Clearance

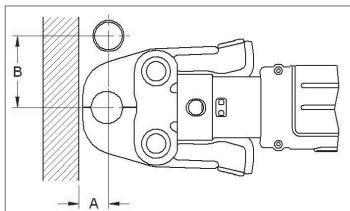

Pipe Diameter	A minimum	B minimum
1/2"	1	2 5/8"
3/4"	1 1/4"	3 1/8"
1"	1 3/4"	3 5/8"

### MegaPress Compact Jaws Clearance

Pipe Diameter	A minimum	B minimum
1/2"	1 1/4"	2 7/8"
3/4"	1 1/8"	3"

**MegaPress Standard Jaws Clearance Between Pipe, Wall, and Floor**

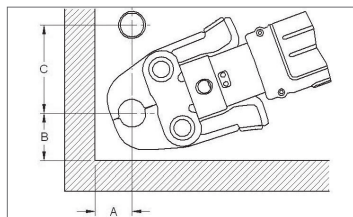

Pipe Diameter	A minimum	B minimum	C minimum
1/2"	1 1/4"	1 7/8"	3"
3/4"	1 1/2"	2 1/8"	3 1/2"
1"	2"	2 1/2"	4"

**MegaPress Compact Jaws Clearance Between Pipe, Wall, and Floor**

Pipe Diameter	A minimum	B minimum	C minimum
1/2"	1 1/2"	2 1/8"	3 1/8"
3/4"	1 3/8"	2 1/8"	3 3/8"

**MegaPress Rings Dimensions**

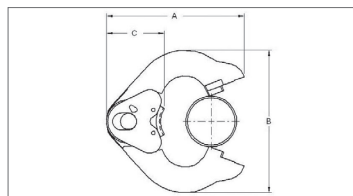

Pipe Diameter	A minimum	B minimum	C minimum
1 1/4"	6"	6 1/4"	2 1/2"
1 1/2"	6"	6 3/4"	2 5/8"
2"	6"	6 7/8"	2 1/2"
2 1/2"	5 5/8"	7 5/8"	2 1/2"
3"	7 1/2"	8 3/8"	2 1/2"
4"	8 1/2"	10 3/8"	2 5/8"

**MegaPress Rings with V2/V3 Actuator Clearance**

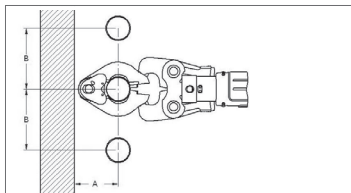

Pipe Diameter	A minimum	B minimum
1 1/4"	3 3/4"	4 7/8"
1 1/2"	4"	5 1/8"
2"	4"	5 3/8"
2 1/2"	4 1/2"	5 7/8"
3"	4 3/4"	6 3/4"
4"	5 3/8"	8 1/4"

**MegaPress Rings with V2/V3 Actuator Clearance Between Pipe, Wall, and Floor**

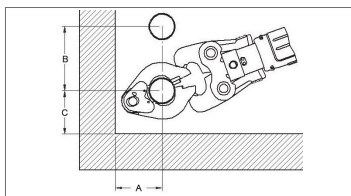

Pipe Diameter	A minimum	B minimum	C minimum
1 1/4"	3 3/4"	3 3/4"	4 7/8"
1 1/2"	4"	4"	5 1/8"
2"	4"	4"	5 3/8"
2 1/2"	4 1/2"	5 7/8"	4"
3"	4 3/4"	6 3/4"	4 3/4"
4"	5 3/8"	8 1/4"	5 1/2"

## Pressing with Ring and Actuator in Tight Quarters

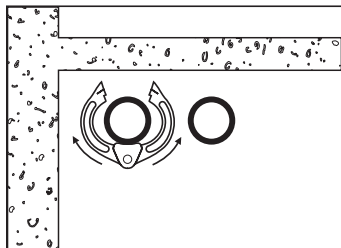

1. Wrap the actuator ring around the press fitting with the opening facing away from you.

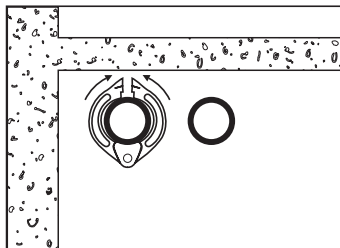

2. Close the actuator tight around the fitting.

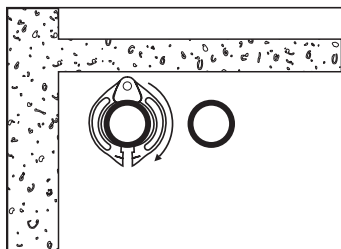

3. Rotate the actuator ring until the press jaw receptacle is facing toward you.

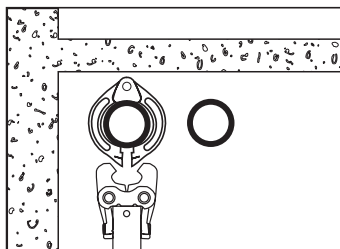

4. Properly insert press jaws and begin the press fitting procedure.

## Dimensional Documentation

### MegaPress Stainless ½" to 2"



## MegaPress 90° Elbow, Stainless Steel, P x P - Models 4116 / 5116

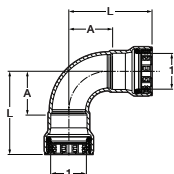

Part No.		Size (in)	A (in)	L (in)
304	316	1		
95005	90005	½	1.17	2.24
95010	90010	¾	1.36	2.52
95015	90015	1	1.72	3.07
95785	90835	1¼	1.96	3.82
95020	90020	1½	2.26	4.13
95025	90025	2	2.80	4.78

## MegaPress 90° Elbow, Stainless Steel, P x FTG - Models 4116.1 / 5116.1

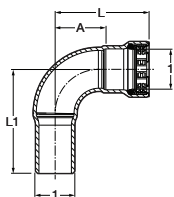

Part No.		Size (in)	A (in)	L (in)	L1 (in)
304	316	1			
95030	90030	½	1.17	2.24	2.56
95035	90035	¾	1.36	2.52	2.87
95040	90040	1	1.72	3.07	3.39
95845	90895	1¼	1.96	3.82	4.04
95045	90045	1½	2.26	4.13	4.21
95050	90050	2	2.80	4.78	5.08

## MegaPress 45° Elbow, Stainless Steel, P x P - Models 4126 / 5126

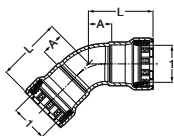

Part No.		Size (in)	A (in)	L (in)
304	316	1		
95055	90055	½	0.60	1.67
95060	90060	¾	0.71	1.87
95065	90065	1	0.86	2.20
95790	90840	1¼	0.94	2.80
95070	90070	1½	1.12	2.99
95075	90075	2	1.32	3.31

## MegaPress 45° Elbow, Stainless Steel, P x FTG - Models 4126.1 / 5126.1

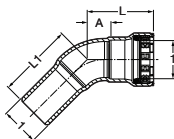

Part No.		Size (in)	A (in)	L (in)	L1 (in)
304	316	1			
95080	90080	½	0.60	1.67	1.97
95085	90085	¾	0.71	1.87	2.13
95090	90090	1	0.86	2.20	2.52
95850	90900	1¼	0.94	2.80	2.99
95095	90095	1½	1.12	2.99	3.07
95100	90100	2	1.32	3.31	3.58



## MegaPress Tee, Stainless Steel, P x P x P - Models 4118 / 5118

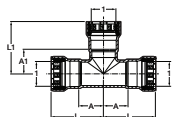

Part No.		Size (in)	A (in)	A1 (in)	L (in)	L1 (in)
304	316	1				
95105	90105	½	0.97	0.93	2.04	2.00
95110	90110	¾	1.11	1.09	2.26	2.24
95115	90115	1	1.23	1.23	2.57	2.57
95795	90845	1¼	1.41	1.38	3.27	3.24
95120	90120	1½	1.57	1.54	3.44	3.41
95125	90125	2	1.81	1.80	3.80	3.79

## MegaPress Reducing Tee, Stainless Steel, P x P x P - Models 4118 / 5118

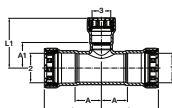

Part No.		Size (in)	A (in)	A1 (in)	L (in)	L1 (in)
304	316	1 2 3				
95130	90130	¾ x ¾ x ½	1.11	1.07	2.26	2.14
95135	90135	1 x 1 x ½	1.23	1.20	2.57	2.28
95140	90140	1 x 1 x ¾	1.23	1.24	2.57	2.40
95855	90905	1¼ x 1¼ x ½	1.41	1.31	3.27	2.42
95860	90910	1¼ x 1¼ x ¾	1.41	1.35	3.27	2.55
95865	90915	1¼ x 1¼ x 1	1.41	1.34	3.27	2.73
95145	90145	1½ x 1½ x ½	1.57	1.44	3.44	2.51
95150	90150	1½ x 1½ x ¾	1.57	1.48	3.44	2.64
95155	90155	1½ x 1½ x 1	1.57	1.48	3.44	2.83
95160	90160	2 x 2 x ½	1.81	1.74	3.80	2.81
95165	90165	2 x 2 x ¾	1.81	1.80	3.80	2.95
95170	90170	2 x 2 x 1	1.81	1.75	3.80	3.10
95175	90175	2 x 2 x 1½	1.81	1.84	3.80	3.71

## MegaPress Reducing Tee, Stainless Steel, P x P x FPT - Models 4117.2 / 5117.2

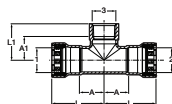

Part No.		Size (in)	A (in)	A1 (in)	L (in)	L1 (in)
304	316	1 2 3				
95180	90180	¾ x ¾ x ½	1.11	1.02	2.26	1.55
95185	90185	¾ x ¾ x ¾	1.11	1.03	2.26	1.58
95190	90190	1 x 1 x ½	1.23	1.19	2.57	1.73
95195	90195	1 x 1 x ¾	1.23	1.18	2.57	1.73
95200	90200	1½ x 1½ x ½	1.57	1.42	3.44	1.95
95205	90205	1½ x 1½ x ¾	1.57	1.41	3.44	1.97
95210	90210	1½ x 1½ x 1	1.57	1.57	3.44	2.24
95215	90215	2 x 2 x ½	1.81	1.70	3.80	2.24
95220	90220	2 x 2 x ¾	1.81	1.72	3.80	2.28
95225	90225	2 x 2 x 1	1.81	1.89	3.80	2.55

## MegaPress Adapter, Stainless Steel, P x MPT - Models 4111 / 5111

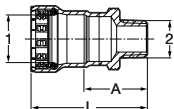

Part No.		Size (in)		A (in)	L (in)
304	316	1	2		
95230	90230	½ x ½		1.45	2.52
95235	90235	¾ x ½		1.49	2.65
95240	90240	¾ x ¾		1.50	2.66
95245	90245	1 x 1		1.66	3.00
95830	90880	1¼ x 1¼		1.85	3.70
95250	90250	1½ x 1½		1.93	3.80
95255	90255	2 x 2		1.93	3.92

## MegaPress Adapter, Stainless Steel, P x FPT - Models 4112 / 5112

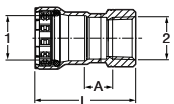

Part No.		Size (in)		A (in)	L (in)
304	316	1	2		
95260	90260	½ x ½		0.69	2.29
95265	90265	¾ x ¾		0.74	2.45
95270	90270	1 x 1		0.73	2.74
95835	90885	1¼ x 1¼		0.73	3.27
95275	90275	1½ x 1½		0.72	3.28
95280	90280	2 x 2		0.76	3.44

## MegaPress Coupling with Stop, Stainless Steel, P x P - Models 4115 / 5115

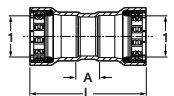

Part No.		Size (in)		A (in)	L (in)
304	316	1			
95285	90285	½		0.56	2.70
95290	90290	¾		0.63	2.94
95295	90295	1		0.59	3.29
95800	90850	1¼		0.70	4.42
95300	90300	1½		0.89	4.63
95305	90305	2		0.77	4.75

## MegaPress Coupling No Stop, Stainless Steel, P x P - Models 4115.5 / 5115.5

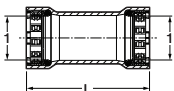

Part No.		Size (in)		L (in)
304	316	1		
95310	90310	½		2.71
95315	90315	¾		2.94
95320	90320	1		3.29
95805	90855	1¼		4.42
95325	90325	1½		4.63
95330	90330	2		4.74

## MegaPress Reducer, Stainless Steel, P x P - Models 4115.2 / 5115.2

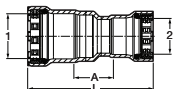

Part No.		Size (in)		A (in)	L (in)
304	316	1	2		
95335	90335	3/4	1 1/2	1.20	3.43
95340	90340	1	3/4	1.24	3.74
95820	90870	1 1/4	1	1.19	4.43
95345	90345	1 1/2	1	1.35	4.57
95350	90350	2	1 1/2	1.43	5.26

## MegaPress Reducer, Stainless Steel, FTG x P - Models 4115.1 / 5115.1

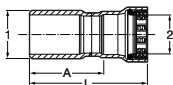

Part No.		Size (in)		A (in)	L (in)
304	316	1	2		
95355	90355	3/4	1 1/2	1.78	2.85
95360	90360	1	1 1/2	2.14	3.21
95365	90365	1	3/4	2.09	3.24
95810	90860	1 1/4	1	2.64	4.02
95815	90865	1 1/2	1 1/4	2.66	4.52
95370	90370	1 1/2	3/4	2.98	4.13
95375	90375	1 1/2	1	2.81	4.16
95380	90380	2	1	3.14	4.49
95385	90385	2	1 1/2	2.96	4.83

## MegaPress Union, Stainless Steel, P x P - Models 4160 / 5160

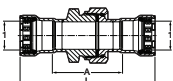

Part No.		Size (in)		A (in)	L (in)
304	316	1			
95415	90415	1/2		2.35	4.50
95420	90420	3/4		2.67	4.99
95425	90425	1		2.65	5.34
95875	90925	1 1/4		2.76	6.48
95430	90430	1 1/2		2.89	6.63
95435	90435	2		3.92	7.89

## MegaPress Flange, Stainless Steel, P x BP - Models 4159 / 5159

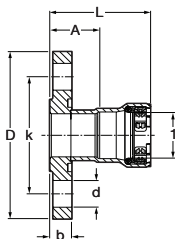

Part No.	Size (in)	A (in)	L (in)	b (in)	k (in)	D (in)	d (in)
<b>304</b>	<b>316</b>	<b>1</b>					
95440	90440	1/2	1.51	2.58	0.46	2.36	3.54
95445	90445	3/4	1.58	2.74	0.52	2.76	3.94
95450	90450	1	1.75	3.10	0.58	3.11	4.33
95870	90875	1 1/4	1.72	3.57	0.64	3.50	4.53
95455	90455	1 1/2	2.06	3.93	0.70	3.86	4.92
95460	90460	2	2.07	4.06	0.77	4.76	5.91

## MegaPress Cap, Stainless Steel, P x Cap - Models 4156 / 5156

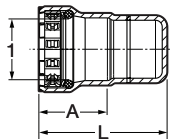

Part No.	Size (in)	A (in)	L (in)
<b>304</b>	<b>316</b>	<b>1</b>	
95390	90390	1/2	1.07
95395	90395	3/4	1.16
95400	90400	1	1.35
95825	90875	1 1/4	1.86
95405	90405	1 1/2	1.87
95410	90410	2	1.99

## MegaPress 3-Piece Ball Valve, Stainless Steel, P x P - Models 4175.8 / 5175.8

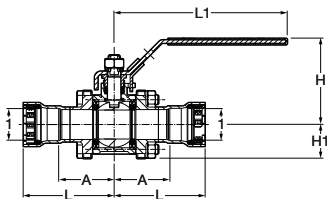

Part No.	Size (in)	A (in)	L (in)	L1 (in)	H (in)	H1 (in)
<b>304</b>	<b>316</b>	<b>1</b>				
86500	86530	1/2	1.72	2.80	5.88	2.85
86505	86535	3/4	1.91	3.06	5.88	2.93
86510	86540	1	2.19	3.54	7.54	3.33
86515	86545	1 1/4	2.50	4.31	7.54	3.57
86520	86550	1 1/2	2.92	4.79	7.54	3.89
86525	86555	2	3.09	5.07	7.54	3.89

## Dimensional Documentation

# MegaPress Stainless 2½" to 4"



## MegaPress Stainless 90° Elbow P x P - Model 4116XL/5116XL

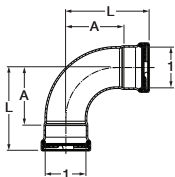

Part No.		Size (in)	A (in)	L (in)
304	316	1		
95500	90500	2½	4.15	5.94
95505	90505	3	4.76	7.09
95510	90510	4	6.00	9.17

## MegaPress Stainless 90° Street Elbow P x FTG - Model 4116.1XL/5116.1XL

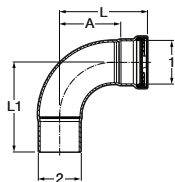

Part No.		Size (in)	A (in)	L (in)	L1 (in)
304	316	1 2			
95515	90515	2½ x 2½	4.15	5.94	6.06
95520	90520	3 x 3	4.76	7.09	6.81
95525	90525	4 x 4	6.00	9.17	8.78

## MegaPress Stainless 45° Elbow P x P - Model 4126XL/5126XL

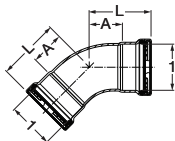

Part No.		Size (in)	A (in)	L (in)
304	316	1		
95530	90530	2½	2.10	3.90
95535	90535	3	2.26	4.56
95540	90540	4	2.74	5.89

## MegaPress Stainless 45° Street Elbow P x FTG - Model 4126.1XL/5126.1XL

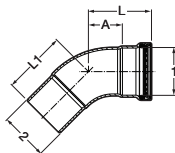

Part No.		Size (in)	A (in)	L (in)	L1 (in)
304	316	1 2			
95545	90545	2½ x 2½	2.10	3.90	3.95
95550	90550	3 x 3	2.26	4.56	4.34
95555	90555	4 x 4	2.74	5.89	5.62

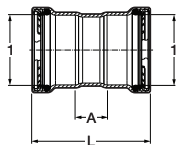
**MegaPress Stainless Coupling with Stop P x P - Model 4115XL/5115XL**

Part No.		Size (in)	A (in)	L (in)
<b>304</b>	<b>316</b>	<b>1</b>		
95645	90645	2½	1.32	4.92
95650	90650	3	1.38	5.98
95655	90655	4	1.57	7.87

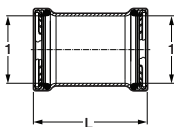
**MegaPress Stainless Coupling No Stop P x P - Model 4115.5XL/5115.5XL**

Part No.		Size (in)	L (in)
<b>304</b>	<b>316</b>	<b>1</b>	
95660	90660	2½	4.92
95665	90665	3	5.98
95670	90670	4	7.91

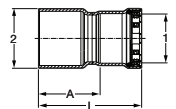
**MegaPress Stainless Reducer FTG x P - Model 4115.1XL/5115.1XL**

Part No.		Size (in)	A (in)	L (in)
<b>304</b>	<b>316</b>	<b>1 2</b>		
95675	90675	2½ x 2	2.97	4.96
95680	90680	3 x 2	3.76	5.75
95685	90685	3 x 2½	3.75	5.55
95690	90690	4 x 2	5.28	7.27
95695	90695	4 x 2½	5.27	7.06
95700	90700	4 x 3	5.03	7.33

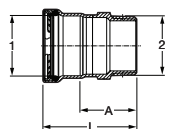
**MegaPress Stainless Adapter P x MPT - Model 4111XL/5111XL**

Part No.		Size (in)	A (in)	L (in)
<b>304</b>	<b>316</b>	<b>1 2</b>		
95635	90635	2½ x 2½	2.75	4.55
95640	90640	3 x 3	2.89	5.20
95735	90735	4 x 4	3.03	6.21

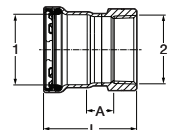
**MegaPress Stainless Adapter P x FPT - Model 4112XL/5112XL**

Part No.		Size (in)	A (in)	L (in)
<b>304</b>	<b>316</b>	<b>1 2</b>		
95770	90740	2½ x 2½	1.13	3.86
95775	90745	3 x 3	1.17	4.49
95780	90750	4 x 4	1.15	5.42

## MegaPress Stainless Tee P x P x P - Model 4118XL/5118XL

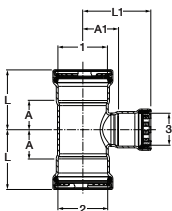

Part No.		Size (in)			A (in)	A1 (in)	L (in)	L1 (in)
304	316	1	2	3				
95575	90575	2½	2½	1½	1.72	2.08	3.52	3.95
95580	90580	2½	2½	2	2.16	2.05	3.96	4.04
95560	90560	2½	2½	2½	2.16	2.26	3.96	4.06
95590	90590	3	3	1½	1.80	2.33	4.13	4.20
95585	90585	3	3	2	2.11	2.30	4.41	4.29
95595	90595	3	3	2½	2.32	2.51	4.63	4.31
95565	90565	3	3	3	2.55	2.52	4.88	4.82
95600	90600	4	4	1½	1.86	2.90	5.04	4.77
95605	90605	4	4	2	2.18	2.87	5.35	4.86
95610	90610	4	4	2½	2.40	3.08	5.55	4.88
95615	90615	4	4	3	2.66	3.13	5.81	5.43
95570	90570	4	4	4	3.22	3.08	6.40	6.26

## MegaPress Stainless Tee P x P x FPT - Model 4117.2XL/5117.2XL

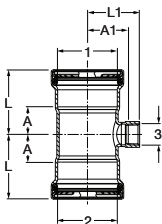

Part No.		Size (in)			A (in)	A1 (in)	L (in)	L1 (in)
304	316	1	2	3				
95620	90620	2½	2½	¾	1.35	2.00	3.15	2.55
95625	90625	3	3	¾	1.44	2.24	3.74	2.80
95630	90630	4	4	¾	1.55	2.76	4.72	3.31

## MegaPress Stainless Cap P - Model 4156.1XL/5156.1XL

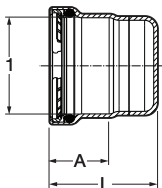

Part No.		Size (in)	A (in)	L (in)
304	316	1		
95705	90705	2½	1.80	3.27
95710	90710	3	2.30	3.82
95715	90715	4	3.18	4.67



## MegaPress Stainless Adapter Flange P - Model 4159XL/5159XL

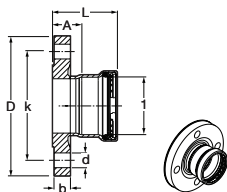

Part No.	Size (in)	A (in)	L (in)	b (in)	k (in)	D (in)	d (in)	
<b>304</b>	<b>316</b>	<b>1</b>						
95720	90720	2½	1.54	3.33	0.89	5.51	7.09	0.75
95725	90725	3	1.65	3.95	0.96	5.98	7.48	0.75

## MegaPress Stainless Adapter Flange P - Model 4159XL/5159XL

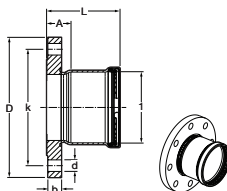

Part No.	Size (in)	A (in)	L (in)	b (in)	k (in)	D (in)	d (in)	
<b>304</b>	<b>316</b>	<b>1</b>						
95730	90730	4	1.63	4.80	0.96	7.52	9.06	0.75



**Q** What is Smart Connect technology?

**A** Smart Connect technology provides a quick and easy way to identify unpressed connections during the pressure testing process. Unpressed connections are located by pressurizing the system with air or water. When testing with air or water, the pressure range is 15 psi to 85 psi maximum. The flow path is removed during the pressing process, creating a leak-proof, reliable connection. Guaranteed.

**Q** Why is Smart Connect technology so valuable?

**A** Smart Connect technology provides the user with a strong peace of mind. It allows for faster testing procedures since you do not have to shut down and drain the system. Costly damages and possible insurance claims and premiums can be avoided because it identifies unpressed connections before they can become a problem. Because of the time savings, projects stay on track.

**Q** Do I need additional equipment to install Viega MegaPress stainless systems?

**A** No. Viega designed Viega MegaPress stainless fittings to be compatible with the same jaws and press tools that are used for the Viega MegaPress carbon steel system.

**Q** If a leak is discovered, is it necessary to drain the system prior to pressing the connection?

**A** No. It is not necessary to drain the system when making a repair.

**Q** How would an inspector know they are looking at a good connection?

**A** Good connections can be proven by performing a pressure test, using the same procedure for a fitting system.

**Q** What is the lubrication used on the sealing elements?

**A** The sealing elements are lubricated with a USDA-approved H1 lubricant, meeting the requirement of FDA 21CFR. If it is necessary to lubricate the seals in the field, use water only. Do not use petroleum-based lubricants. Petroleum and EPDM are incompatible.

**Q** How long will the EPDM seal last?

**A** When properly installed, the EPDM seal and connection will last as long as the piping system.

**Q** How do I fabricate a system in tight places when using Viega MegaPress?

**A** If necessary, prefabricate connections that are in tight places and then install.

**Q** What is the warranty for Viega MegaPress stainless fittings?

**A** Viega MegaPress stainless fittings carry a 2-year warranty against defects in material and workmanship from Viega.

**Q** How do Viega MegaPress stainless connections hold up to freezing temperatures?

**A** Precautions should be taken for any piping system to protect the system from below-freezing temperatures.

**Q** What level of turbulence occurs in Viega MegaPress stainless fittings and will it cause premature wear in the piping?

**A** The long radius of Viega MegaPress elbows reduces turbulence typically experienced with traditional short-radius fittings. Not reaming the ID of the pipe is the largest contributing factor to turbulence and premature wear of any piping system.

## Viega Metal Systems for Industrial Applications

**Industrial applications are defined as non-residential and non-commercial applications not normally accessible to the general public, including manufacturing, mining, process or fabrication environments.**

Subject to the terms and conditions of this Limited Warranty, Viega LLC (Viega) warrants to end users, installers and distribution houses that its Viega metal press products (Viega product) when properly installed in industrial applications shall be free from failure caused by manufacturing defects for a period of two (2) years from date of installation.

Under this Limited Warranty, you only have a right to a remedy if the failure or leak resulted from a manufacturing defect in the Viega product and the failure or leak occurs during the warranty period. You do not have a remedy under this warranty and the warranty remedy does not apply if the failure or any resulting damage is caused by (1) components other than those sold by Viega; (2) not designing, installing, inspecting, testing, or maintaining the Viega product in accordance with Viega's installation and product instructions in effect at the time of installation and other specifications and approvals applicable to the installation; (3) improper handling and protection of the Viega product prior to, during and after installation, inadequate freeze protection, or exposure to environmental or operating conditions not recommended for the application; or (4) acts of nature, such as, but not limited to earthquakes, fire, or weather damage.

Final approval as to use compatibility to a specific process or fluid application is the responsibility of the engineer of record or responsible design/facilities personnel and this Limited Warranty only applies to manufacturing defects in the Viega Product.

In the event of a leak or other failure in the Viega product covered by this warranty, it is the responsibility of the end user to take appropriate measures to diminish any damage, to include making timely repairs. Only if the warranty applies will Viega be responsible for the remedy under this warranty. The part or parts which you claim failed should be kept and Viega contacted by writing to the address below or telephoning 1-800-976-9819 within thirty (30) calendar days after the leak or other failure and identifying yourself as having a warranty claim. You should be prepared to ship, at your expense, the product which you claim failed due to a manufacturing defect, document the date of installation, and the amount of the repair or replacement if performed by you. Within a reasonable time after receiving the product, Viega will investigate the reasons for the failure, which includes the right to inspect the product at a Viega location and reasonable access to the site of damage. Viega will notify you in writing as to the results of its review.

In the event that Viega determines that the failure or leak was the result of a manufacturing defect in the Viega Product covered by this warranty and to which this warranty applies, the EXCLUSIVE AND ONLY REMEDY under this warranty shall be the reimbursement for reasonable charges for repair or replacement of the Viega Product itself. VIEGA SHALL NOT BE LIABLE FOR CONSEQUENTIAL OR OTHER DAMAGE (FOR EXAMPLE, ECONOMIC LOSS, WATER OR PROPERTY OR MOLD REMEDIATION) UNDER ANY LEGAL THEORY AND WHETHER ASSERTED BY DIRECT ACTION, FOR CONTRIBUTION OR INDEMNITY OR OTHERWISE.

THE ABOVE WARRANTY IS IN LIEU OF ALL OTHER WARRANTIES, EXPRESS OR IMPLIED, INCLUDING, BUT NOT LIMITED TO, THE IMPLIED WARRANTIES OR ANY STATUTE OF LIMITATIONS RELATING TO SUCH WARRANTIES. Other than this Limited Warranty, Viega does not authorize any person or firm to create for it any other obligation or liability in connection with its products.

This Limited Warranty gives you specific legal rights and you also may have other rights which may vary from state to state. This warranty shall be interpreted and applied under the law of the state in which the product is installed and is intended as a Commercial Warranty.

## Viega Marine Applications

**Marine applications are defined as mobile structures used to navigate water or stationary structures in water**

Subject to the terms and conditions of this Limited Warranty, Viega LLC (Viega) warrants to end users, installers and distribution houses that its Viega metal press products (Viega product) when properly installed in approved marine applications and other products sold by Viega LLC when properly installed in marine applications in accordance with our listings shall be free from failure caused by manufacturing defects for a period of two (2) years from date of installation. This warranty applies only to approved applications. Installations that are not approved shall not be covered by this warranty and shall not be the responsibility of Viega LLC.

Under this Limited Warranty, you only have a right to a remedy if the failure or leak resulted from a manufacturing defect in the Viega product and the failure or leak occurs during the warranty period. You do not have a remedy under this warranty and the warranty remedy does not apply if the failure or any resulting damage is caused by (1) components other than those sold by Viega; (2) not designing, installing, inspecting, testing, or maintaining the Viega product in accordance with Viega's installation and product instructions in effect at the time of installation and other specifications and approvals applicable to the installation; (3) improper handling and protection of the Viega product prior to, during and after installation, inadequate freeze protection, or exposure

to environmental or operating conditions not recommended for the application; or (4) acts of nature, such as, but not limited to earthquakes, fire, or weather damage. Final approval as to use compatibility to a specific process or fluid application is the responsibility of the engineer of record or responsible design/facilities personnel and this Limited Warranty only applies to manufacturing defects in the Viega Product.

In the event of a leak or other failure in the Viega product covered by this warranty, it is the responsibility of the end user to take appropriate measures to diminish any damage, to include making timely repairs. Only if the warranty applies will Viega be responsible for the remedy under this warranty. The part or parts which you claim failed should be kept and Viega contacted by writing to the address below or telephoning 1-800-976-9819 within thirty (30) calendar days after the leak or other failure and identifying yourself as having a warranty claim. You should be prepared to ship, at your expense, the product which you claim failed due to a manufacturing defect, document the date of installation, and the amount of the repair or replacement if performed by you. Within a reasonable time after receiving the product, Viega will investigate the reasons for the failure, which includes the right to inspect the product at a Viega location and reasonable access to the site of damage. Viega will notify you in writing as to the results of its review.

In the event that Viega determines that the failure or leak was the result of a manufacturing defect in the Viega Product covered by this warranty and to which this warranty applies, the EXCLUSIVE AND ONLY REMEDY under this warranty shall be the reimbursement for reasonable charges for repair or replacement of the Viega Product itself. VIEGA SHALL NOT BE LIABLE FOR CONSEQUENTIAL OR OTHER DAMAGE (FOR EXAMPLE, ECONOMIC LOSS, WATER OR PROPERTY OR MOLD REMEDIATION) UNDER ANY LEGAL THEORY AND WHETHER ASSERTED BY DIRECT ACTION, FOR CONTRIBUTION OR INDEMNITY OR OTHERWISE.

THE ABOVE WARRANTY IS IN LIEU OF ALL OTHER WARRANTIES, EXPRESS OR IMPLIED, INCLUDING, BUT NOT LIMITED TO, THE IMPLIED WARRANTIES OR ANY STATUTE OF LIMITATIONS RELATING TO SUCH WARRANTIES.

Other than this Limited Warranty, Viega does not authorize any person or firm to create for it any other obligation or liability in connection with its products.

This Limited Warranty gives you specific legal rights and you also may have other rights which may vary from state to state. This warranty shall be interpreted and applied under the law of the state in which the product is installed and is intended as a Commercial Warranty.



**Viega LLC**

585 Interlocken Blvd  
Broomfield, CO 80021

Ph: 800-976-9819  
Fax: 800-976-9817  
[www.viega.us](http://www.viega.us)

