

RS150 GNSS

INSTALLATION INSTRUCTIONS

English (EN)

Date: 05-2017

Document number: 87271-2

© 2017 Raymarine UK Limited

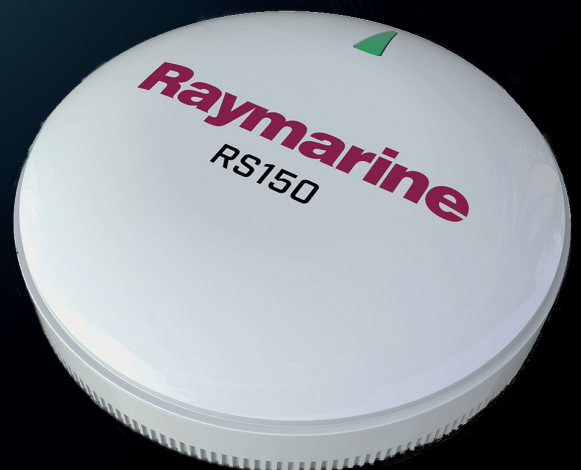

Raymarine[®]
BY  **FLIR**

Trademark and patents notice

Raymarine, Tacktick, Clear Pulse, Truzoom, HSB, SeaTalk, SeaTalk^{hs}, SeaTalk^{ng}, Micronet, Raytech, Gear Up, Marine Shield, Seahawk, Autohelm, Automagic, and Visionality are registered or claimed trademarks of Raymarine Belgium.

FLIR, LightHouse, DownVision, SideVision, RealVision, Dragonfly, Quantum, Instalert, Infrared Everywhere, The World's Sixth Sense and ClearCruise are registered or claimed trademarks of FLIR Systems, Inc.

All other trademarks, trade names, or company names referenced herein are used for identification only and are the property of their respective owners.

This product is protected by patents, design patents, patents pending, or design patents pending.

Fair Use Statement

You may print no more than three copies of this manual for your own use. You may not make any further copies or distribute or use the manual in any other way including without limitation exploiting the manual commercially or giving or selling copies to third parties.

Software updates



Check the Raymarine website for the latest software releases for your product.
www.raymarine.com/software

Product documentation



The latest versions of all English and translated documents are available to download in PDF format from the website: www.raymarine.com/manuals.
Please check the website to ensure you have the latest documentation.

Copyright ©2017 Raymarine UK Ltd. All rights reserved.

Contents

Chapter 1 Important information..... 7

Water ingress	7
Disclaimer.....	7
Suppression ferrites	7
Connections to other equipment	8
Declaration of conformity.....	8
Product disposal.....	8
Warranty registration	8
IMO and SOLAS.....	8
Technical accuracy	8

Chapter 2 Document and product information..... 9

2.1 Document information	10
Applicable products.....	10
Document illustrations.....	10
Operation instructions	10
2.2 RS150 product overview	10
SeaTalkng®.....	10

Chapter 3 Planning the installation.....11

3.1 Installation checklist	12
Schematic diagram	12
3.2 Parts supplied.....	12
3.3 Software updates	13
3.4 Tools required for installation.....	13
3.5 Warnings and cautions.....	14
3.6 Selecting a location	14
GNSS Receiver location requirements	14
RF interference	14
Compass safe distance.....	15
EMC installation guidelines	15
3.7 Product dimensions.....	16

Chapter 4 Cables and connections 17

4.1 General cabling guidance.....	18
Cable types and length	18
Routing cables	18
Strain relief.....	18
Cable shielding.....	18
4.2 Connections overview	18
Connecting SeaTalkng® cables	18

SeaTalkng® product loading	18
4.3 SeaTalkng® power supply.....	19
SeaTalkng® power connection point	19
In-line fuse and thermal breaker ratings	19
SeaTalkng® system loading.....	19
Power distribution — SeaTalkng®.....	19
Sharing a breaker.....	20
4.4 NMEA 2000 network connection	21
4.5 SeaTalkng® network example	22

Chapter 5 Installation 23

5.1 Surface mounting	24
5.2 Pole or rail mounting	24
5.3 Surface mounting using the Deck mounting kit.....	25
5.4 Bracket mounting using the Deck mounting kit.....	26
5.5 Surface mounting using the Riser	27
5.6 Releasing the unit from the adaptor	28

Chapter 6 System checks and troubleshooting 29

6.1 Initial test	30
GPS Status	30
6.2 Troubleshooting.....	32
GNSS troubleshooting	33
LED Diagnostics.....	34

Chapter 7 Maintenance 35

7.1 Service and maintenance.....	36
7.2 Routine equipment checks	36
7.3 Product cleaning.....	37

Chapter 8 Technical support 39

8.1 Raymarine product support and servicing	40
Viewing product information.....	40
8.2 Learning resources.....	41

Chapter 9 Technical specification..... 43

9.1 Technical specification.....	44
----------------------------------	----

Chapter 10 Spares and accessories	45
10.1 Accessories	46
10.2 SeaTalk ^{ng} ® cabling components.....	46
10.3 SeaTalk ^{ng} ® cables and accessories	47
 Appendix A NMEA 2000 PGN support	 49

Chapter 1: Important information



Warning: Product installation and operation

- This product must be installed and operated in accordance with the instructions provided. Failure to do so could result in personal injury, damage to your vessel and/or poor product performance.
- Raymarine recommends certified installation by a Raymarine approved installer. A certified installation qualifies for enhanced product warranty benefits. Contact your Raymarine dealer for further details, and refer to the separate warranty document packed with your product.



Warning: Potential ignition source

This product is NOT approved for use in hazardous/flammable atmospheres. Do NOT install in a hazardous/flammable atmosphere (such as in an engine room or near fuel tanks).



Warning: Product grounding

Before applying power to this product, ensure it has been correctly grounded, in accordance with the instructions provided.



Warning: Positive ground systems

Do not connect this unit to a system which has positive grounding.



Warning: Switch off power supply

Ensure the vessel's power supply is switched OFF before starting to install this product. Do NOT connect or disconnect equipment with the power switched on, unless instructed in this document.



Warning: Power supply voltage

Connecting this product to a voltage supply greater than the specified maximum rating may cause permanent damage to the unit. Refer to the *Technical specification* section for voltage rating.

Caution: Power supply protection

When installing this product ensure the power source is adequately protected by means of a suitably-rated fuse or automatic circuit breaker.

Caution: Product cleaning

When cleaning products:

- Lightly rinse or flush with clean, cool fresh water.
- If your product has a display screen, do NOT wipe the screen with a dry cloth, as this could scratch the screen coating.
- Do NOT use: abrasive, acidic, ammonia, solvent of chemical based cleaning products.
- Do NOT use a jet wash.

Caution: Service and maintenance

This product contains no user serviceable components. Please refer all maintenance and repair to authorized Raymarine dealers. Unauthorized repair may affect your warranty.

Water ingress

Water ingress disclaimer

Although the waterproof rating capacity of this product meets the stated IPX standard (refer to the product's *Technical Specification*), water intrusion and subsequent equipment failure may occur if the product is subjected to commercial high-pressure washing. Raymarine will not warrant products subjected to high-pressure washing.

Disclaimer

Raymarine does not warrant that this product is error-free or that it is compatible with products manufactured by any person or entity other than Raymarine.

Raymarine is not responsible for damages or injuries caused by your use or inability to use the product, by the interaction of the product with products manufactured by others, or by errors in information utilized by the product supplied by third parties.

Suppression ferrites

- Raymarine cables may be pre-fitted or supplied with suppression ferrites. These are important for correct EMC performance. If ferrites are supplied separately to the cables (i.e. not pre-fitted), you

must fit the supplied ferrites, using the supplied instructions.

- If a ferrite has to be removed for any purpose (e.g. installation or maintenance), it must be replaced in the original position before the product is used.
- Use only ferrites of the correct type, supplied by Raymarine or its authorized dealers.
- Where an installation requires multiple ferrites to be added to a cable, additional cable clips should be used to prevent stress on the connectors due to the extra weight of the cable.

Technical accuracy

To the best of our knowledge, the information in this document was correct at the time it was produced. However, Raymarine cannot accept liability for any inaccuracies or omissions it may contain. In addition, our policy of continuous product improvement may change specifications without notice. As a result, Raymarine cannot accept liability for any differences between the product and this document. Please check the Raymarine website (www.raymarine.com) to ensure you have the most up-to-date version(s) of the documentation for your product.

Connections to other equipment

Requirement for ferrites on non-Raymarine cables

If your Raymarine equipment is to be connected to other equipment using a cable not supplied by Raymarine, a suppression ferrite **MUST** always be attached to the cable near the Raymarine unit.

Declaration of conformity

Raymarine UK Ltd. declares that this product is compliant with the essential requirements of EMC directive 2004/108/EC.

The original Declaration of Conformity certificate may be viewed on the relevant product page at www.raymarine.com.

Product disposal

Dispose of this product in accordance with the WEEE Directive.



■ The Waste Electrical and Electronic Equipment (WEEE) Directive requires the recycling of waste electrical and electronic equipment.

Warranty registration

To register your Raymarine product ownership, please visit www.raymarine.com and register online.

It is important that you register your product to receive full warranty benefits. Your unit package includes a bar code label indicating the serial number of the unit. You will need this serial number when registering your product online. You should retain the label for future reference.

IMO and SOLAS

The equipment described within this document is intended for use on leisure marine boats and workboats NOT covered by International Maritime Organization (IMO) and Safety of Life at Sea (SOLAS) Carriage Regulations.

Chapter 2: Document and product information

Chapter contents

- [2.1 Document information on page 10](#)
- [2.2 RS150 product overview on page 10](#)

2.1 Document information

This document contains important information related to the installation of your Raymarine product.

The document includes information to help you:

- plan your installation and ensure you have all the necessary equipment;
- install and connect your product as part of a wider system of connected marine electronics;
- troubleshoot problems and obtain technical support if required.

This and other Raymarine product documents are available to download in PDF format from www.raymarine.com.

Applicable products

This document is applicable to the following products:

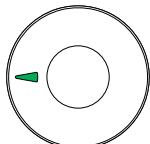
	Part number	Name	Description
	E70310	RS150	SeaTalk^{ng} GNSS (GPS- /GLONASS) Receiver

Document illustrations

Your product may differ slightly from that shown in the illustrations in this document, depending on product variant and date of manufacture.

All images are provided for illustration purposes only.

Product documentation

The following documentation is applicable to your product:

Description	Part number
RS150 Installation instructions Installation of a RS150 and connection to a wider system of marine electronics.	87271
RS150 Mounting template Mounting diagram for mounting a RS150.	87272

Operation instructions

For detailed operation instructions for your product, refer to the documentation that accompanies your display.

2.2 RS150 product overview

The RS150 is a SeaTalkng® Global Navigation Satellite Systems (GNSS) Receiver. The RS150 provides position data to devices connected to the SeaTalkng® network. When used in conjunction with a SeaTalk and SeaTalkng® converter the RS150 can also provide position data to SeaTalk devices.

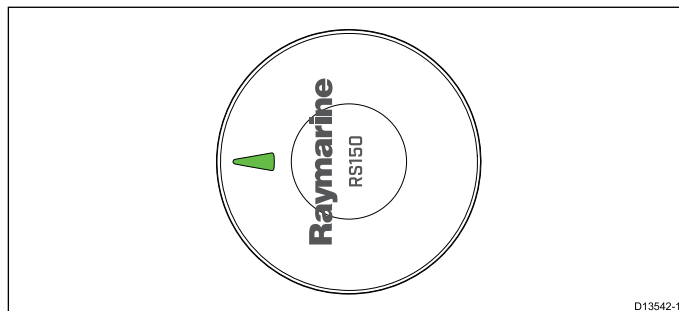

The **RS150** has the following features:

- Compatible with GPS and GLONASS GNSS systems
- BeiDou and Galileo ready (supported by future software update)
- Pole, Rail, Surface or Bracket mountable (mounting kits available)
- 10Hz refresh rate
- NMEA 2000 compliant
- Low power consumption
- 12V DC operation (24V protection)
- Waterproof to IPx6

SeaTalkng®

SeaTalkng® (Next Generation) is an enhanced protocol for connection of compatible marine instruments and equipment. It replaces the older SeaTalk and SeaTalk2 protocols.

SeaTalkng® utilizes a single backbone to which compatible equipment connect using a spur. Data and power are carried within the backbone. Devices that have a low draw can be powered from the network, although high current equipment will need to have a separate power connection.

SeaTalkng® is a proprietary extension to NMEA 2000 and the proven CAN bus technology. Compatible NMEA 2000 and SeaTalk and SeaTalk2 devices can also be connected using the appropriate interfaces or adaptor cables as required.

Chapter 3: Planning the installation

Chapter contents

- [3.1 Installation checklist on page 12](#)
- [3.2 Parts supplied on page 12](#)
- [3.3 Software updates on page 13](#)
- [3.4 Tools required for installation on page 13](#)
- [3.5 Warnings and cautions on page 14](#)
- [3.6 Selecting a location on page 14](#)
- [3.7 Product dimensions on page 16](#)

3.1 Installation checklist

Installation includes the following activities:

Installation Task	
1	Plan your system.
2	Obtain all required equipment and tools.
3	Site all equipment.
4	Route all cables.
5	Drill cable and mounting holes.
6	Make all connections into equipment.
7	Secure all equipment in place.
8	Power on and test the system.

Schematic diagram

A schematic diagram is an essential part of planning any installation. It is also useful for any future additions or maintenance of the system. The diagram should include:

- Location of all components.
- Connectors, cable types, routes and lengths.

3.2 Parts supplied

The following parts are supplied with your product.

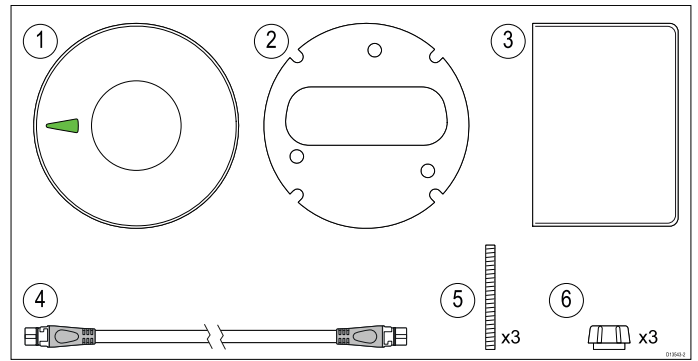

1. Unit
2. Mounting gasket
3. Documentation
4. 6 m (19.69 ft) SeaTalkng® (White) cable
5. M4 x 40mm Threaded studs x 3 (used for surface mounting)
6. Finger nuts x 3 (used for surface mounting)

Unpack your product carefully to prevent damage or loss of parts, check the box contents against the list above. Retain the packaging and documentation for future reference.

3.3 Software updates

The software running on the product can be updated.

- Raymarine periodically releases software updates to improve product performance and add new features.
- The software on many products can be updated using a connected and compatible multifunction display (MFD).
- Refer to www.raymarine.com/software/ for the latest software updates and the software update procedure for your specific product.

Important:

- To prevent potential software-related issues with your product, always follow the relevant update instructions carefully and in the sequence provided.
- If in doubt as to the correct procedure for updating your product software, refer to your dealer or Raymarine technical support.

Caution: Installing software updates

The software update process is carried out at your own risk. Before initiating the update process ensure you have backed up any important files.

Ensure that the unit has a reliable power supply and that the update process is not interrupted.

Damage caused by incomplete updates are not covered by Raymarine warranty.

By downloading the software update package, you agree to these terms.

3.4 Tools required for installation

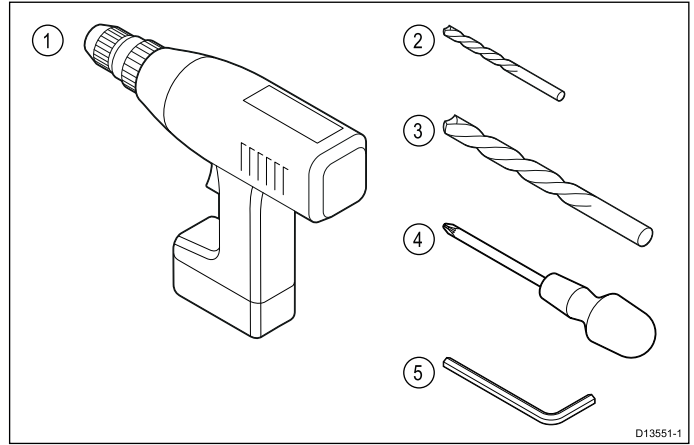

1	Power drill
2	4 mm (11/64) drill bit (for fixing studs)
3	22 mm (for cable hole when surface mounting)
4	Pozi-drive screwdriver (only required for Pole mount installations)
5	Size 4 (2.5 mm) Hex Key (only required for Pole mount installations)

3.5 Warnings and cautions

Important: Before proceeding, ensure that you have read and understood the warnings and cautions provided in the [Chapter 1 Important information](#) section of this document.

3.6 Selecting a location



Warning: Potential ignition source

This product is NOT approved for use in hazardous/flammable atmospheres. Do NOT install in a hazardous/flammable atmosphere (such as in an engine room or near fuel tanks).

GNSS Receiver location requirements

When planning the installation location, consider the following:

- The GNSS Receiver is waterproof, and appropriate for above decks mounting.
- Choose a location that provides the most unobstructed view of the sky in all directions:

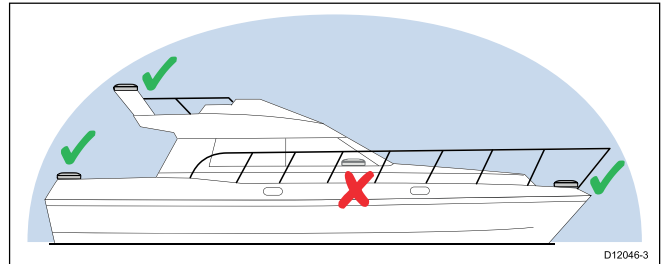

- The GNSS Receiver must be mounted on a level horizontal surface.
- Do NOT mount the GNSS Receiver at the top of a mast.
- The GNSS Receiver should be mounted at least 1 m (3 ft) away from devices that may cause interference, such as motors, generators, VHF radio units and other transmitters / receivers.
- Ensure the GNSS Receiver is NOT mounted in the path of the beam emitted from Radar scanners.
- Safe from physical damage and excessive vibration.
- Away from any source of heat.
- Away from any potential flammable hazard, such as fuel vapors.

RF interference

Certain third-party external electrical equipment can cause Radio Frequency (RF) interference with GPS, AIS or VHF devices if the external equipment is not adequately insulated and emits excessive levels of electromagnetic interference (EMI).

Some common examples of such external equipment include LED spot or strip lights, and terrestrial TV tuners.

To minimize interference from such equipment:

- Keep it as far away from GPS, AIS or VHF devices as possible.
- Ensure that any power cables for external equipment are not entangled with the power or data cables for GPS, AIS or VHF devices.
- Consider fitting one or more high frequency suppression ferrites to the EMI-emitting device.

The ferrite(s) should be rated to be effective in the range 100 MHz to 2.5 GHz, and should be fitted to the power cable and any other cables exiting the EMI-emitting device, as close as possible to the position where the cable exits the device.

Note: Where constraints on the installation prevent any of the above recommendations, always ensure the maximum possible separation between different items of electrical equipment, to provide the best conditions for EMC performance throughout the installation

Compass safe distance

To prevent potential interference with the vessel's magnetic compasses, ensure an adequate distance is maintained from the product.

When choosing a suitable location for the product you should aim to maintain the maximum possible distance from any compasses. Typically this distance should be at least 1 m (3 ft) in all directions. However for some smaller vessels it may not be possible to locate the product this far away from a compass. In this situation, when choosing the installation location for your product, ensure that the compass is not affected by the product when it is in a powered state.

EMC installation guidelines

Raymarine equipment and accessories conform to the appropriate Electromagnetic Compatibility (EMC) regulations, to minimize electromagnetic interference between equipment and minimize the effect such interference could have on the performance of your system

Correct installation is required to ensure that EMC performance is not compromised.

Note: In areas of extreme EMC interference, some slight interference may be noticed on the product. Where this occurs the product and the source of the interference should be separated by a greater distance.

For **optimum** EMC performance we recommend that wherever possible:

- Raymarine equipment and cables connected to it are:
 - At least 1m (3ft) from any equipment transmitting or cables carrying radio signals e.g. VHF radios, cables and antennas. In the case of SSB radios, the distance should be increased to 7 ft (2 m).
 - More than 2m (7ft) from the path of a radar beam. A radar beam can normally be assumed to spread 20 degrees above and below the radiating element.
- The product is supplied from a separate battery from that used for engine start. This is important to prevent erratic behavior and data loss which can occur if the engine start does not have a separate battery.
- Raymarine specified cables are used.
- Cables are not cut or extended, unless doing so is detailed in the installation manual.

3.7 Product dimensions

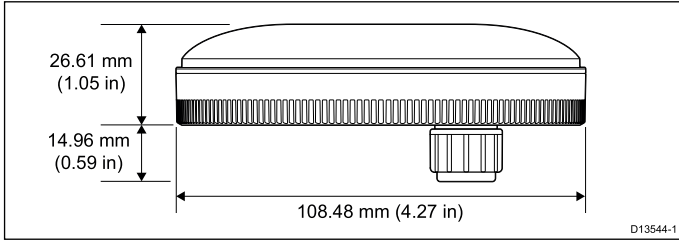

Chapter 4: Cables and connections

Chapter contents

- [4.1 General cabling guidance on page 18](#)
- [4.2 Connections overview on page 18](#)
- [4.3 SeaTalkng® power supply on page 19](#)
- [4.4 NMEA 2000 network connection on page 21](#)
- [4.5 SeaTalkng® network example on page 22](#)

4.1 General cabling guidance

Cable types and length

It is important to use cables of the appropriate type and length

- Unless otherwise stated use only standard cables of the correct type, supplied by Raymarine.
- Ensure that any non-Raymarine cables are of the correct quality and gauge. For example, longer power cable runs may require larger wire gauges to minimize voltage drop along the run.

Routing cables

Cables must be routed correctly, to maximize performance and prolong cable life.

- Do NOT bend cables excessively. Wherever possible, ensure a minimum bend diameter of 200 mm (8 in) / minimum bend radius of 100 mm (4 in).

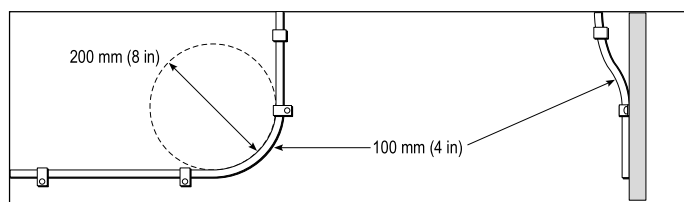

- Protect all cables from physical damage and exposure to heat. Use trunking or conduit where possible. Do NOT run cables through bilges or doorways, or close to moving or hot objects.
- Secure cables in place using tie-wraps or lacing twine. Coil any extra cable and tie it out of the way.
- Where a cable passes through an exposed bulkhead or deckhead, use a suitable watertight feed-through.
- Do NOT run cables near to engines or fluorescent lights.

Always route data cables as far away as possible from:

- other equipment and cables,
- high current carrying AC and DC power lines,
- antennae.

Strain relief

Ensure adequate strain relief is provided. Protect connectors from strain and ensure they will not pull out under extreme sea conditions.

Cable shielding

Ensure that all data cables are properly shielded that the cable shielding is intact (e.g. hasn't been scraped off by being squeezed through a tight area).

4.2 Connections overview

Your product includes the following connectors.

Connector	Qty	Connects to:	Suitable cables
	1	1. SeaTalkng backbone 2. NMEA 2000 backbone	1. SeaTalkng spur cables 2. SeaTalkng to DeviceNet adaptor cable (A06045)

Connecting SeaTalkng® cables

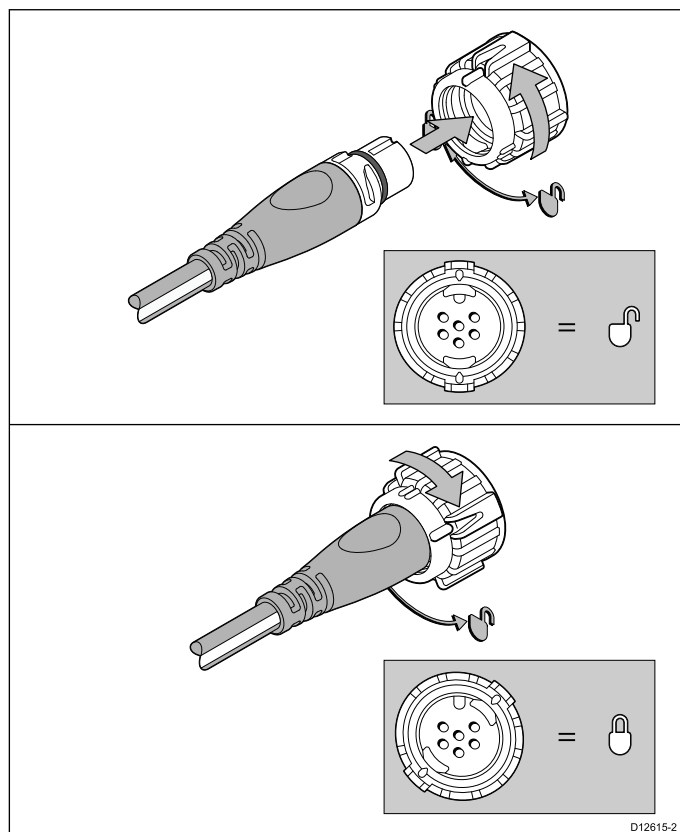

1. Rotate the locking collar on the unit to the unlocked position.
2. Ensure the cable's connector is correctly oriented.
3. Fully insert the cable connector.
4. Rotate locking collar clockwise (2 clicks) until it is in the locked position.

SeaTalkng® product loading

The number of products that can be connected to a SeaTalkng® backbone depends on the power consumption of each product and the physical overall length of the backbone.

SeaTalkng® products have a Load Equivalency Number (LEN), which indicates the product's power consumption. The LEN for each product can be found in the product's Technical Specification.

4.3 SeaTalkng® power supply

Power is supplied to the product over the SeaTalkng® backbone.

A SeaTalkng® backbone requires only one 12 V dc power supply, connected to the SeaTalkng® backbone. This can be provided by one of the following:

- a battery ⁽¹⁾, via the distribution panel;
- an Autopilot Control Unit (ACU)⁽²⁾;
- an SPX course computer ⁽²⁾;
- for 24 V vessels a 5 amp, regulated, continuous 24 V dc to 12 V dc converter is required.

Note:

- (1) The battery used for starting the vessel's engine(s) should NOT be used to power the SeaTalkng® backbone, as this can cause sudden voltage drops when the engines are started.
- (2) The ACU-100, ACU-150 or SPX-5 products cannot be used to power the SeaTalkng® backbone.

SeaTalkng® power connection point

Small systems

If the backbone length is 60 m (197 ft) or less, the power connection point may be connected at any point in the backbone.

Large systems

If the backbone length is greater than 60 m (197 ft), the power connection point should be connected at a point that creates a balanced current draw from each side of the backbone. The Load Equivalency Number (LEN) is used to determine the power connection point for the system.

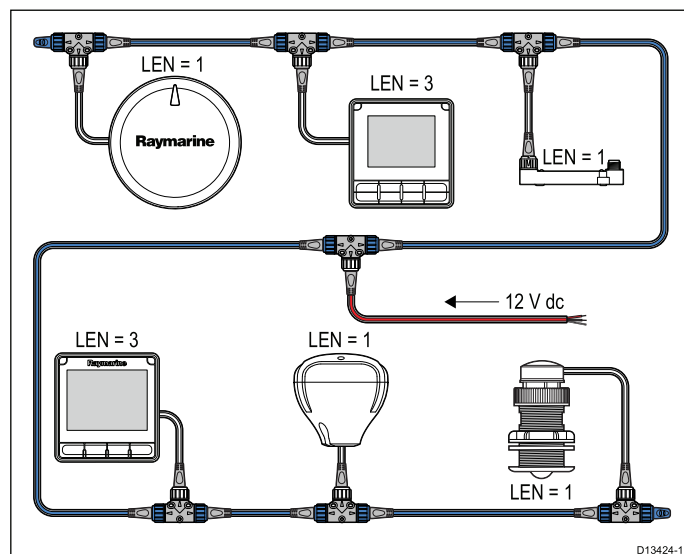

In the example above the system has an overall LEN of 10, so the optimum connection point would be to have 5 LEN either side of the connection point.

In-line fuse and thermal breaker ratings

The SeaTalkng® network's power supply requires an in-line fuse or thermal breaker to be fitted.

In-line fuse rating	Thermal breaker rating
5 A	3 A (if only connecting one device)

Note:

The suitable fuse rating for the thermal breaker is dependent on the number of devices you are connecting. If in doubt consult an authorized Raymarine dealer.

SeaTalkng® system loading

The maximum loading / LEN for a SeaTalkng® system depends on the length of the backbone.

Loading type	Backbone length	Total LEN
Unbalanced	20 m (66 ft)	40
Unbalanced	40 m (131 ft)	20
Unbalanced	60 m (197 ft)	14
Balanced	60 m (197 ft) or less	100
Balanced	80 m (262 ft)	84
Balanced	100 m (328 ft)	60
Balanced	120 m (394 ft)	50
Balanced	140 m to 160 m (459 ft to 525 ft)	40
Balanced	180 m to 200 m (591 ft to 656 ft)	32

Power distribution — SeaTalkng®

Recommendations and best practice.

- Only use approved SeaTalkng® power cables. Do NOT use a power cable designed for, or supplied with, a different product.
- See below for more information on implementation for some common power distribution scenarios.

Important:

When planning and wiring, take into consideration other products in your system, some of which (e.g. sonar modules) may place large power demand peaks on the vessel's electrical system.

Note:

The information provided below is for guidance only, to help protect your product. It covers common vessel power arrangements, but does NOT cover every scenario. If you are unsure how to provide the correct level of protection, please consult an authorized Raymarine dealer or a suitably qualified professional marine electrician.

Implementation — direct connection to battery

- SeaTalkng® power cables may be connected directly to the vessel's battery, via a suitably rated fuse or breaker.
- You MUST fit a suitably rated fuse or breaker between the red wire and the battery's positive terminal.
- Refer to the inline fuse ratings provided in the product's documentation.
- If you need to extend the length of the power cable, ensure you use suitably rated cable and that sufficient power (12 V dc) is available at the SeaTalkng® backbone's power connection.

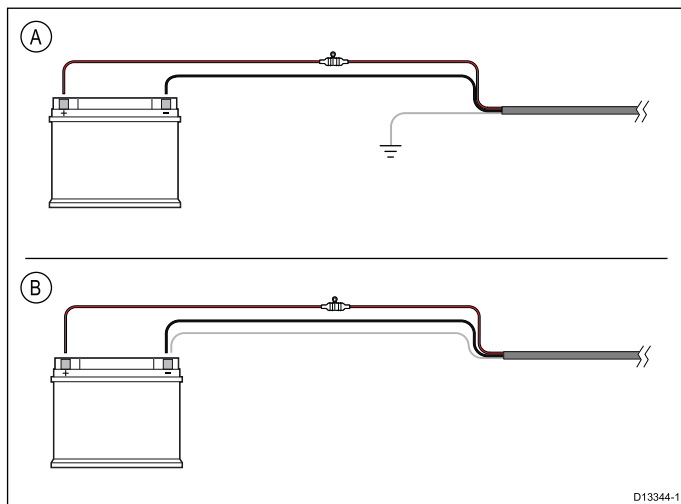

A	Battery connection scenario A: suitable for a vessel with a common RF ground point. In this scenario, if your product's power cable is supplied with a separate drain wire then it should be connected to the vessel's common ground point.
B	Battery connection scenario B: suitable for a vessel without a common grounding point. In this case, if your product's power cable is supplied with a separate drain wire then it should be connected directly to the battery's negative terminal.

Implementation — connection to distribution panel

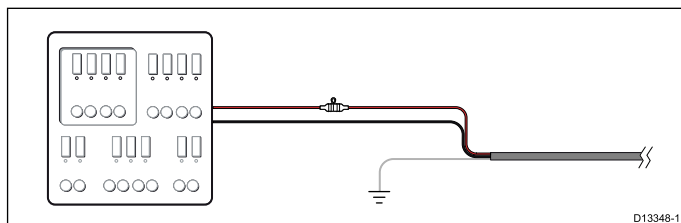

- Alternatively, the SeaTalkng® power cable may be connected to a suitable breaker or switch on the vessel's distribution panel or factory-fitted power distribution point.
- The distribution point should be fed from the vessel's primary power source by 8 AWG (8.36 mm²) cable.
- Ideally, all equipment should be wired to individual suitably-rated thermal breakers or fuses, with appropriate circuit protection. Where this is not possible and more than 1 item of equipment shares a breaker, use individual in-line fuses

for each power circuit to provide the necessary protection.

- In all cases, observe the recommended breaker / fuse ratings provided in the product's documentation.
- If you need to extend the length of the power cable, ensure you use suitably rated cable and that sufficient power (12 V dc) is available at the SeaTalkng® backbone's power connection.

Important:

Be aware that the suitable fuse rating for the thermal breaker or fuse is dependent on the number of devices you are connecting.

More information

It is recommended that best practice is observed in all vessel electrical installations, as detailed in the following standards:

- BMEA Code of Practice for Electrical and Electronic Installations in Boats
- NMEA 0400 Installation Standard
- ABYC E-11 AC & DC Electrical Systems on Boats
- ABYC A-31 Battery chargers and Inverters
- ABYC TE-4 Lightning Protection

Sharing a breaker

Where more than 1 piece of equipment shares a breaker you must provide protection for the individual circuits. E.g. by connecting an in-line fuse for each power circuit.

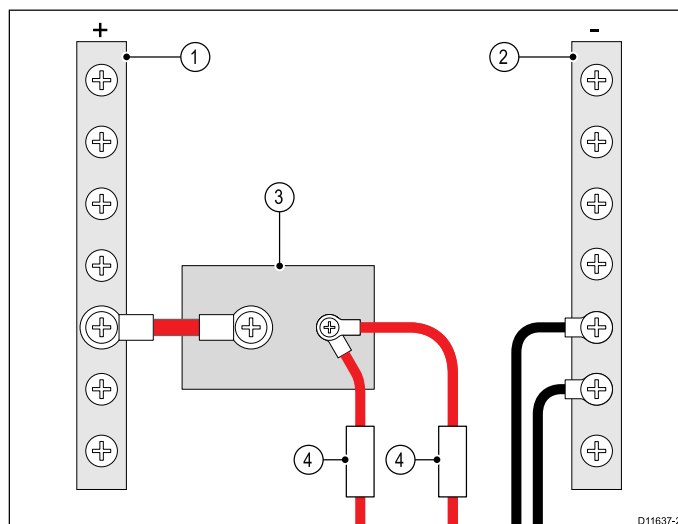

1	Positive (+) bar
2	Negative (-) bar
3	Circuit breaker
4	Fuse

Where possible, connect individual items of equipment to individual circuit breakers. Where this is not possible, use individual in-line fuses to provide the necessary protection.



Warning: Product grounding

Before applying power to this product, ensure it has been correctly grounded, in accordance with the instructions provided.



Warning: Positive ground systems

Do not connect this unit to a system which has positive grounding.

4.4 NMEA 2000 network connection

Your **SeaTalk^{ng}**® device can be connected to a **DeviceNet / NMEA 2000** network.

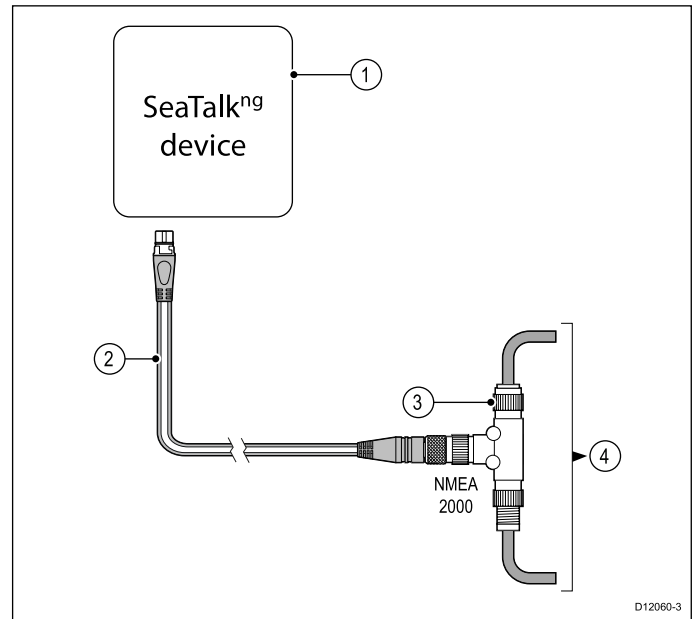

1. **SeaTalk^{ng}**® device
2. **SeaTalk^{ng}**® to **DeviceNet** adaptor cable (A06045)
3. **DeviceNet** T-piece
4. **NMEA 2000** backbone

4.5 SeaTalk^{ng}® network example

Your product provides data to other devices on the **SeaTalk^{ng}®** network.

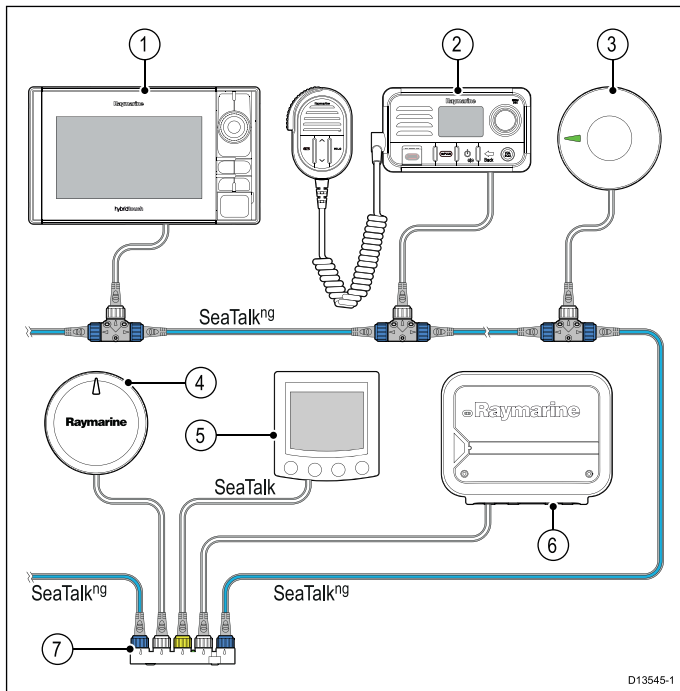

D13545-1

1. **SeaTalk^{ng}®** MFD
2. **SeaTalk^{ng}®** VHF Radio
3. **RS150** GNSS Receiver
4. **Evolution** EV sensor
5. **SeaTalk** Pilot controller
6. **ACU** (Actuator Control Unit)
7. **SeaTalk** to **SeaTalk^{ng}®** converter

Chapter 5: Installation

Chapter contents

- 5.1 Surface mounting on page 24
- 5.2 Pole or rail mounting on page 24
- 5.3 Surface mounting using the Deck mounting kit on page 25
- 5.4 Bracket mounting using the Deck mounting kit on page 26
- 5.5 Surface mounting using the Riser on page 27
- 5.6 Releasing the unit from the adaptor on page 28

5.1 Surface mounting

The unit can be mounted on a surface that is up to approximately 28 mm (1.10 in) thick using the fixings supplied with the unit. To mount on a thicker surface longer studs will be required.

Ensure that the chosen location meets the product's location requirements, see [3.6 Selecting a location](#) for details.

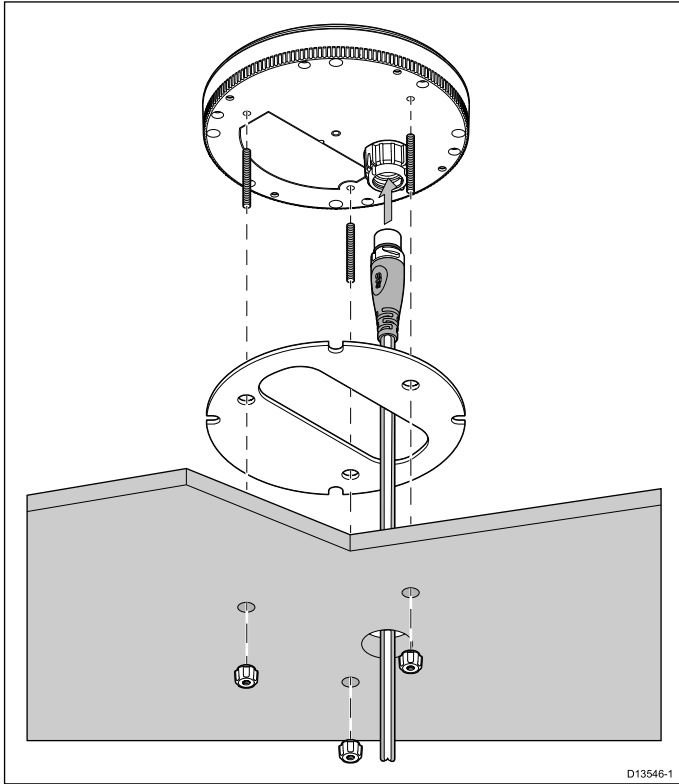

1. Affix the supplied mounting template to the mounting surface at the desired location.
2. Drill 3 x fixing holes and 1 x cable hole using drill bit sizes as indicated on the template.
3. Place the waterproof gasket into position on the underside of the unit.
4. Connect the cable to an available **SeaTalk^{ng}** spur connection then connect the other end to the connector on the underside of the unit and secure using the locking collar.
5. Screw the threaded studs into the underside of the unit (these should be hand-tight only).
6. Position the unit so that the mounting studs pass through the holes in the mounting surface.
7. Secure the unit to the mounting surface using the thumb nuts. (these should be hand-tight only).

5.2 Pole or rail mounting

The Pole mount kit (A80370) can be used to mount your product on a pole or rail.

A pole or rail mount with a 1 inch 14 TPI thread is required.

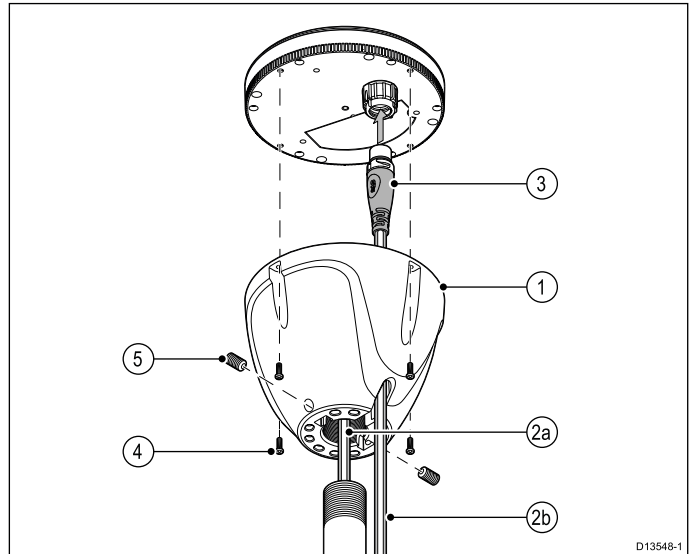

1. Screw the Pole mount adaptor on to the pole.
2. Feed the cable through either:
 - a) the center of the Pole mount adaptor and pole, or
 - b) the cable exit hole.
3. Connect the cable to an available **SeaTalk^{ng}** spur connection then connect the other end of the cable to the connector on the underside of the unit and secure using the locking collar.
4. Ensuring correct orientation, Secure the unit to the Pole mount adaptor using the fixings supplied with the adaptor.
5. Fix the unit's orientation by tightening the grub screws.

The grub screws and their captive nuts are supplied fitted to the adaptor.

5.3 Surface mounting using the Deck mounting kit

The Deck mounting kit (A80437) can be used to surface or bracket mount your product.

The Riser and Bracket pieces are not required for this installation.

Ensure that the chosen location meets the product's location requirements, see [3.6 Selecting a location](#) for details.

7. Place the Mounting trim over the unit slightly offset, and then twist the Mounting trim clockwise until it locks into position.

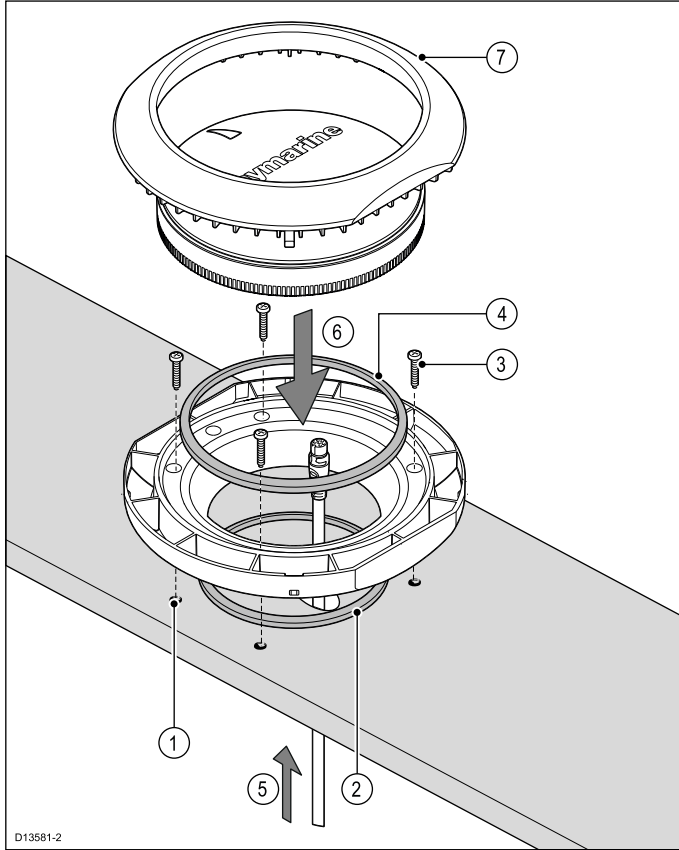
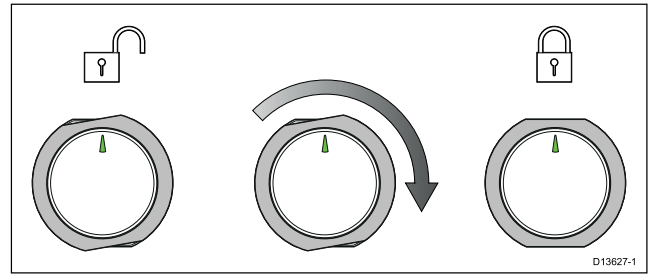

1. Using the Mounting tray template (87170), drill 4 holes in the mounting surface, plus a 22 mm (7/8 in) hole for the SeaTalkng® cable.
2. Place the small sealing ring in the groove located on the bottom of the mounting tray.
3. Secure the tray to the mounting surface using the 4 x fixings, supplied.
4. Place the large sealing ring into the groove on the upper side of the Mounting tray.
5. Pull the SeaTalkng® cable through the mounting surface hole and the Mounting tray. Plug in the cable connector on the underside of the unit and secure by rotating the locking collar clockwise 2 clicks.
6. Insert the unit into the mounting tray, ensuring the tabs in the Mounting tray are slotted into the grooves around the edge of the unit.

Important:

Unit orientation is not important with the RS150, aesthetically the unit may look better with the LED 'arrow' pointing towards the vessel's bow.

5.4 Bracket mounting using the Deck mounting kit

The Deck mounting kit (A80437) can be used to wall mount your product.

The Riser piece is not required for bracket mounting the product.

Ensure that the chosen location meets the product's location requirements, see [3.6 Selecting a location](#) for details.

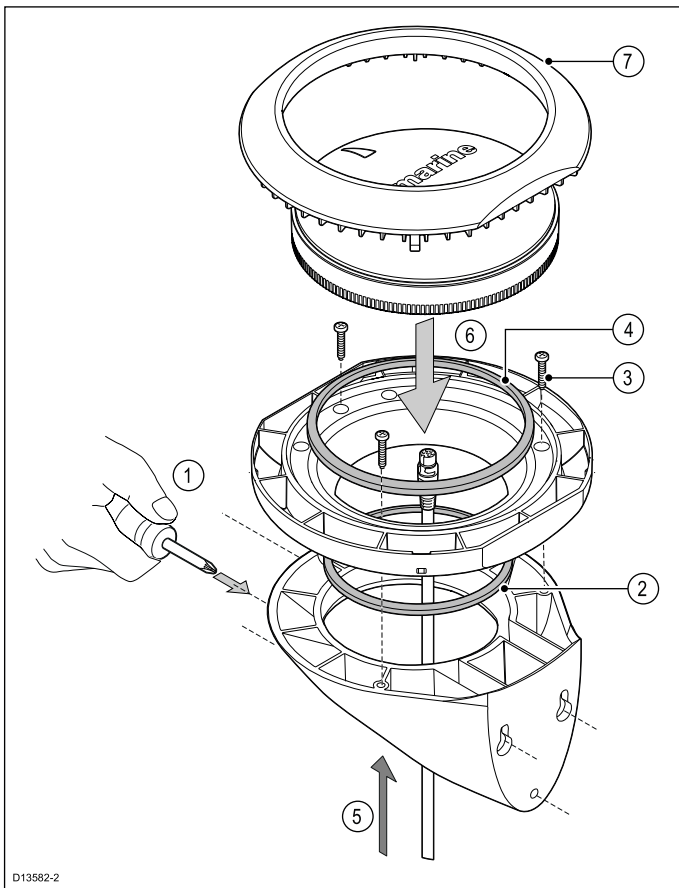

1. Use the Mounting bracket template (87170) to drill 3 pilot holes in the vertical mounting surface. Secure the mounting bracket to the surface using the supplied screws.
2. Place the small sealing ring in the groove located on the bottom of the Mounting tray.
3. Secure the tray to the bracket using 3 of the supplied screws, in the positions indicated in the illustration above.
4. Place the large sealing ring into the groove on the upper side of the Mounting tray.
5. Pull the SeaTalkng® cable through the center of the bracket and tray. Plug in the cable connector on the underside of the unit and secure by rotating the locking collar clockwise 2 clicks.
6. Insert the unit into the mounting tray, ensuring the tabs in the Mounting tray are slotted into the grooves around the edge of the unit.

Important:

Unit orientation is not important with the RS150, aesthetically the unit may look better with the LED 'arrow' pointing towards the vessel's bow.

7. Orientate the Mounting trim so that the release hole is accessible when mounted.

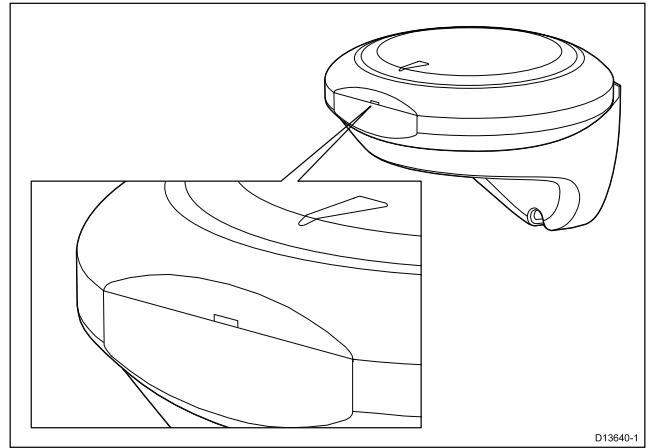

8. Place the Mounting trim over the unit slightly offset, and then twist the Mounting trim clockwise until it locks into position.

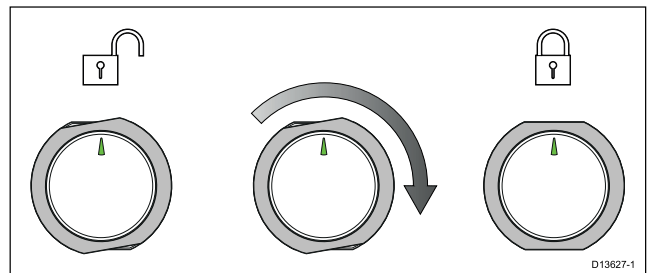

5.5 Surface mounting using the Riser

The Deck mounting kit (A80437) can be used to raise the product from the mounting surface.

The Wall bracket is not required when using the Riser.

Ensure that the chosen location meets the product's location requirements, see [3.6 Selecting a location](#) for details.

- Place the Mounting trim over the unit slightly offset, and then twist the Mounting trim clockwise until it locks into position.

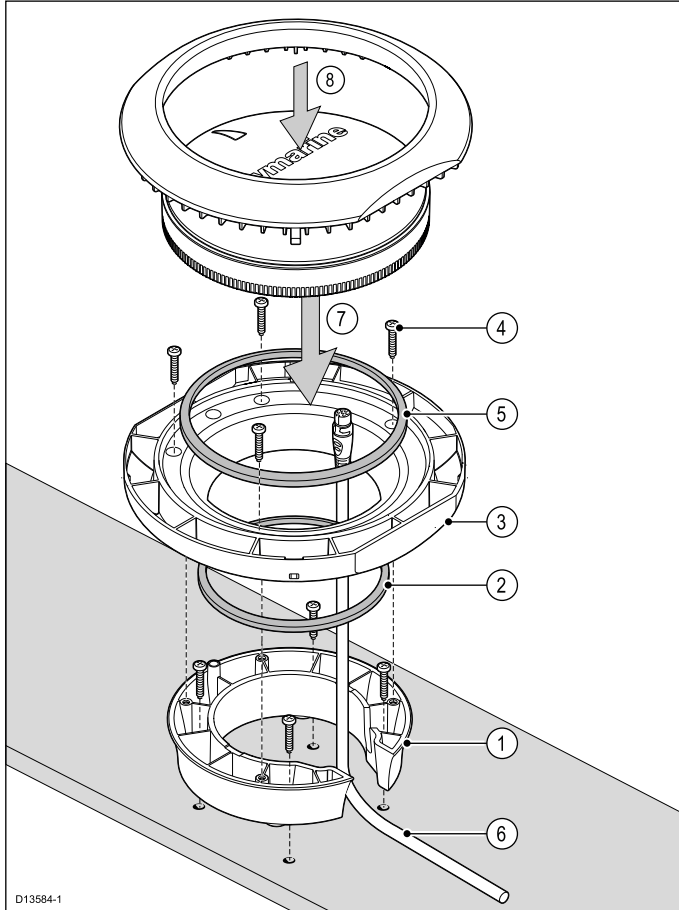
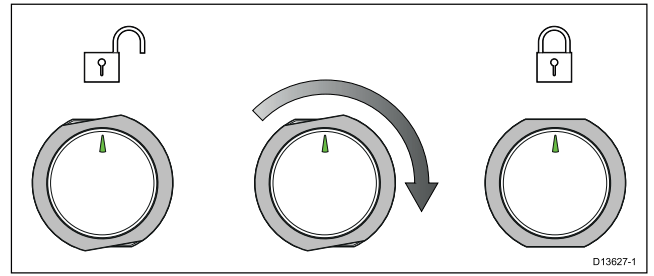

- Use the supplied Deck mount riser template (87280) to drill 4 holes in the mounting surface. Secure the Riser to the mounting surface using 4x supplied fixings.
- Place the small sealing ring in the groove located on the bottom of the mounting tray.
- Position the Mounting tray on top of the Riser.
- Secure the Mounting tray to the Riser using 3x supplied fixings.
- Place the large sealing ring into the groove on the upper side of the Mounting tray.
- Pull the SeaTalkng® cable through the Riser and Mounting tray. Plug in the cable connector on the underside of the unit and secure by rotating the locking collar clockwise 2 clicks.
- Insert the unit into the mounting tray, ensuring the tabs in the Mounting tray are slotted into the grooves around the edge of the unit.

Important:

Unit orientation is not important with the RS150, but aesthetically the unit may look better with the LED 'arrow' pointing towards the vessel's bow.

5.6 Releasing the unit from the adaptor

Follow the steps below to release the unit from the Mounting adaptor.

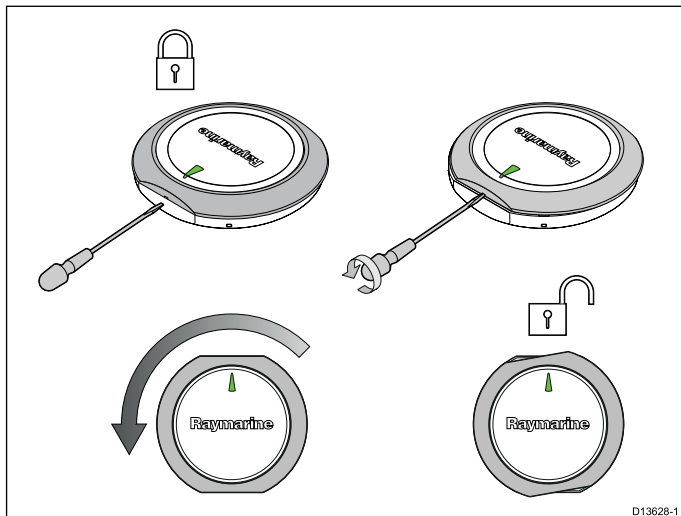

D13628-1

1. Insert the flat of a small flat blade screw driver, or similar tool into the release hole located on the flat edge of the mounting adaptor and twist the screw driver 90°, so that there is a small gap between the Mounting trim and Mounting tray.

Important: To help prevent scratching the product, cover the tip of your screw driver with a small piece of insulation tape.

2. Twist the Mounting trim counter-clockwise approximately 10° and then lift away from the unit.

Chapter 6: System checks and troubleshooting

Chapter contents

- [6.1 Initial test on page 30](#)
- [6.2 Troubleshooting on page 32](#)

6.1 Initial test

Once the unit is fully connected and installed, perform an initial power on test to verify correct operation.

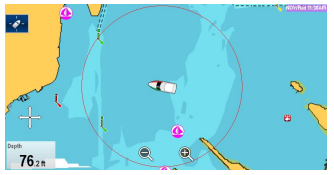
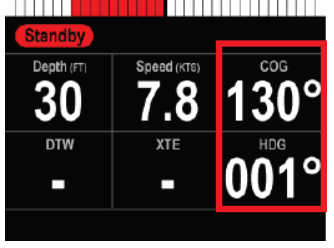
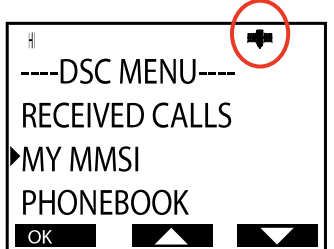
Product type	Unit to use for verifying operation	Application(s) to use for verifying operation	Example screen
GNSS Receiver	MFD	Chart application (check the vessel position displayed on the chart against your actual proximity to a known charted object).	
	Instrument or pilot control head	Check that a position fix is displayed.	
	VHF radio	Check that a position fix is displayed.	

GPS Status

Products with an internal GPS receiver or GNSS (GPS/GLONASS) receiver can use the GPS status page to view the status of the available compatible satellites.

The satellite constellations are used to position your boat in the Chart application. You can set up your receiver and check its status from the menu. For each satellite, the screen provides the following information:

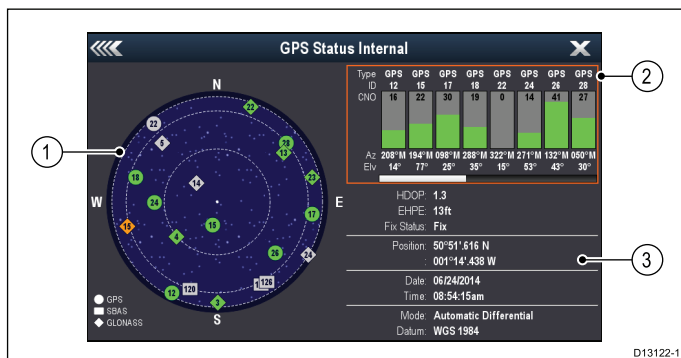

1. Sky view
2. Satellite status
3. Position and fix information

Sky view

Sky view is a visual representation that shows the position of navigation satellites and their type. Satellite types are:

- **Circle** — A circle identifies a satellite from the GPS constellation.
- **Square** — A square identifies an (SBAS) differential satellite.

- **Diamond** — A diamond identifies a satellite from the GLONASS constellation.

Satellite status area

The Satellite status area displays the following information about each satellite:

- **Type** — Identifies which constellation the satellite belongs to.
- **ID** — Displays the satellites identification number.
- **CNO** (Carrier-to-noise ratio) — Displays the signal strength of each satellite shown in the Sky view:
 - Grey = searching for satellite
 - Green = satellite in use
 - Orange = tracking satellite
- **Azimuth and Elevation** — Provides the angle of elevation and azimuth between the location of the receiver and the satellite.

Position and fix information

The following positional and fix information is provided:

- **Horizontal Dilution of Precision (HDOP)** — HDOP is a measure of satellite navigation accuracy, calculated from a number of factors including satellite geometry, system errors in the data transmission and system errors in the receiver. A higher figure signifies a greater positional error. A typical receiver has an accuracy of between 5 and 15 m. As an example, assuming a receiver error of 5 m, an HDOP of 2 would represent an error of approximately 15 m. Please remember that even a very low HDOP figure is NO guarantee that your receiver is providing an

accurate position. If in doubt, check the displayed vessel position in the Chart application against your actual proximity to a known charted object.

- **Estimated Horizontal Position Error (EHPE)**
 - EHPE is a measure of the estimated error of a position fix in the horizontal plane. The value displayed indicates that your position is within a circle radius of the stated size 50% of the time.
- **Fix status** — indicates the actual mode the receiver is reporting:
 - **Fix** — Satellite fix has been acquired.
 - **No Fix** — No satellite fix can be acquired.
 - **D Fix** — A differential beacon fix has been acquired.
 - **SD Fix** — A differential satellite fix has been acquired.
- **Position** — Displays the latitude and longitude position of your receiver.
- **Date / Time** — Displays the current date and time generated by the position fix in UTC format.
- **Mode** — Identifies whether the receiver is working in differential mode or non-differential mode.
- **Datum** — The receiver's datum setting affects the accuracy of the vessel position information displayed in the Chart application. In order for your receiver and MFD to correlate accurately with your paper charts, they must be using the same datum.

6.2 Troubleshooting

The troubleshooting information provides possible causes and corrective action required for common problems associated with installation and operation of your product.

Before packing and shipping, all Raymarine products are subjected to comprehensive testing and quality assurance programs. If you do experience problems with your product this section will help you to diagnose and correct problems in order to restore normal operation.

If after referring to this section you are still having problems with your product, please refer to the Technical support section of this manual for useful links and Raymarine Product Support contact details.

GNSS troubleshooting

Problems with the GNSS and their possible causes and solutions are described here.

Problem	Possible causes	Possible solutions
"No Fix" GNSS status icon is displayed.	Geographic location or prevailing conditions preventing satellite fix.	Check periodically to see if a fix is obtained in better conditions or another geographic location.
	GNSS connection fault.	Ensure that external GNSS connections and cabling are correct and fault free.
	External GNSS receiver in poor location. For example: <ul style="list-style-type: none"> • Below decks. • Close proximity to transmitting equipment such as VHF radio. 	Ensure GNSS receiver has a clear view of the sky.
	GNSS installation problem.	Refer to the installation instructions.
<p>Note: A GNSS Status screen is accessible from the display. This provides satellite signal strength and other relevant information.</p>		

LED Diagnostics

LED Sequence	LED Color	Status
	Green	<ul style="list-style-type: none"> • Bus healthy, no communication bus faults • All sensors connected and ready
	Green	<ul style="list-style-type: none"> • Sensors initializing
	Green	<ul style="list-style-type: none"> • GPS initializing <p>(Can take up to 5 minutes at first use or after factory reset or software update)</p>
	Red	<ul style="list-style-type: none"> • No GPS Signal
	Red	<ul style="list-style-type: none"> • Bus not connected / fault
	Red	<ul style="list-style-type: none"> • Bus connected but not receiving data

Chapter 7: Maintenance

Chapter contents

- [7.1 Service and maintenance on page 36](#)
- [7.2 Routine equipment checks on page 36](#)
- [7.3 Product cleaning on page 37](#)

7.1 Service and maintenance

This product contains no user serviceable components. Please refer all maintenance and repair to authorized Raymarine dealers. Unauthorized repair may affect your warranty.

7.2 Routine equipment checks

It is recommended that you perform the following routine checks, on a regular basis, to ensure the correct and reliable operation of your equipment:

- Examine all cables for signs of damage or wear and tear.
- Check that all cables are securely connected.

7.3 Product cleaning

Best cleaning practices.

When cleaning products:

- Lightly rinse or flush with clean, cool fresh water.
- If your product has a display screen, do NOT wipe the screen with a dry cloth, as this could scratch the screen coating.
- Do NOT use: abrasive, acidic, ammonia, solvent of chemical based cleaning products.
- Do NOT use a jet wash.

Chapter 8: Technical support

Chapter contents

- [8.1 Raymarine product support and servicing on page 40](#)
- [8.2 Learning resources on page 41](#)

8.1 Raymarine product support and servicing

Raymarine provides a comprehensive product support service, as well as warranty, service, and repairs. You can access these services through the Raymarine website, telephone, and e-mail.

Product information

If you need to request service or support, please have the following information to hand:

- Product name.
- Product identity.
- Serial number.
- Software application version.
- System diagrams.

You can obtain this product information using the menus within your product.

Servicing and warranty

Raymarine offers dedicated service departments for warranty, service, and repairs.

Don't forget to visit the Raymarine website to register your product for extended warranty benefits: <http://www.raymarine.co.uk/display/?id=788>.

Region	Tele- phone	E-mail
United Kingdom (UK), EMEA, and Asia Pacific	+44 (0)1329 246 932	emea.service@raymarine.com
United States (US)	+1 (603) 324 7900	rm-usrepair@flir.com

Web support

Please visit the "Support" area of the Raymarine website for:

- **Manuals and Documents** — <http://www.raymarine.com/manuals>
- **FAQ / Knowledgebase** — <http://www.raymarine.com/knowledgebase>
- **Technical support forum** — <http://forum.raymarine.com>
- **Software updates** — <http://www.raymarine.com/software>

Telephone and e-mail support

Region	Tele- phone	E-mail
United Kingdom (UK), EMEA, and Asia Pacific	+44 (0)1329 246 777	support.uk@raymarine.com
United States (US)	+1 (603) 324 7900 (Toll-free: +800 539 5539)	support@raymarine.com

Region	Tele- phone	E-mail
Australia and New Zealand	+61 2 8977 0300	aus.support@raymarine.com (Raymarine subsidiary)
France	+33 (0)1 46 49 72 30	support.fr@raymarine.com (Raymarine subsidiary)
Germany	+49 (0)40 237 808 0	support.de@raymarine.com (Raymarine subsidiary)
Italy	+39 02 9945 1001	support.it@raymarine.com (Raymarine subsidiary)
Spain	+34 96 2965 102	sat@azimut.es (Authorized Raymarine distributor)
Netherlands	+31 (0)26 3614 905	support.nl@raymarine.com (Raymarine subsidiary)
Sweden	+46 (0)317 633 670	support.se@raymarine.com (Raymarine subsidiary)
Finland	+358 (0)207 619 937	support.fi@raymarine.com (Raymarine subsidiary)
Norway	+47 692 64 600	support.no@raymarine.com (Raymarine subsidiary)
Denmark	+45 437 164 64	support.dk@raymarine.com (Raymarine subsidiary)
Russia	+7 495 788 0508	info@mikstmarine.ru (Authorized Raymarine distributor)

Viewing product information

With your MFD Homescreen displayed:

1. Select **Set-up**.
2. Select **Maintenance**.
3. Select **Diagnostics**.
4. Select **Select Device**.
5. Select the relevant product from the list.

The Diagnostics page is displayed.

8.2 Learning resources

Raymarine has produced a range of learning resources to help you get the most out of your products.

Video tutorials

	Raymarine official channel on YouTube: <ul style="list-style-type: none">• http://www.youtube.com/user/RaymarineInc
	Video Gallery: <ul style="list-style-type: none">• http://www.raymarine.co.uk/view/?id=2679
	Product Support videos: <ul style="list-style-type: none">• http://www.raymarine.co.uk/view/?id=4952

Note:

- Viewing the videos requires a device with an Internet connection.
- Some videos are only available in English.

Training courses

Raymarine regularly runs a range of in-depth training courses to help you make the most of your products. Visit the Training section of the Raymarine website for more information:

- <http://www.raymarine.co.uk/view/?id=2372>

FAQs and Knowledge Base

Raymarine has produced an extensive set of FAQs and a Knowledge Base to help you find more information and troubleshoot any issues.

- <http://www.raymarine.co.uk/knowledgebase/>

Technical support forum

You can use the Technical support forum to ask a technical question about a Raymarine product or to find out how other customers are using their Raymarine equipment. The resource is regularly updated with contributions from Raymarine customers and staff:

- <http://forum.raymarine.com>

Chapter 9: Technical specification

Chapter contents

- [9.1 Technical specification on page 44](#)

9.1 Technical specification

Nominal supply voltage	12 V dc (Supplied by SeaTalk^{ng})
Operating voltage range	9 V dc to 16 V dc (protected up to 32 V dc)
Power consumption	30mA max.
Environmental	Installation environment <ul style="list-style-type: none"> • Operating temperature: -25°C to +55°C (-13°F to 131°F) • Storage temperature: -25°C to +70°C (-13°F to 158°F) • Relative humidity: max 93% • Waterproof to IPx6
Conformance	<ul style="list-style-type: none"> • Europe: 2004/108/EC • Australia and New Zealand: C-Tick, Compliance Level 2
Supported connection protocols	<ul style="list-style-type: none"> • SeaTalk^{ng} • NMEA 2000 (via DeviceNet adaptor)
LEN (refer to SeaTalk ^{ng} Reference manual for more information)	1
Signal acquisition	Automatic
Channels	72
Sensitivity	-163 dBm (tracking), -147 dBm (acquisition)
GNSS compatibility	<ul style="list-style-type: none"> • GPS • GLONASS • Galileo ready (via future software update) • Beidou ready (via future software update)
Satellite Differential Type (SBAS)	<ul style="list-style-type: none"> • WAAS (United States) • EGNOS (Europe) • MSAS (Japan) • GAGAN (India)
Differential acquisition	Automatic
Position accuracy without SBAS (95%)	< 15 m
Position accuracy with SBAS (95%)	< 5 m
Speed accuracy (95%)	< 0.3 kt
Time to first fix from cold start	< 2 minutes (< 45 seconds typical)

Time to first fix from hot start	< 8 seconds
Geodetic Datum	WGS84

Chapter 10: Spares and accessories

Chapter contents

- [10.1 Accessories on page 46](#)
- [10.2 SeaTalk^{ng}® cabling components on page 46](#)
- [10.3 SeaTalk^{ng}® cables and accessories on page 47](#)

10.1 Accessories

The following accessories are available:

Accessories

Item	Part number
Pole/rail mounting adaptor kit	A80370
6 m SeaTalk ^{ng} white spur cable	A06072
Deck mounting (Clamshell/Riser) kit	A80437

10.2 SeaTalk^{ng}® cabling components

SeaTalk^{ng} cabling components and their purposes.

Connection / Cable	Notes
Backbone cable (various lengths)	The main cable carrying data. Spurs from the backbone are used to connect SeaTalk ^{ng} devices.
T-piece connector	Used to make junctions in the backbone to which devices can then be connected.
Terminator	Required at either end of the backbone.
Inline terminator	Used to connect a spur cable directly to the end of a backbone; useful for longer cable runs.
Spur cable	Used to connect devices to the backbone. Devices may be daisy chained or connected directly to the T-pieces.
SeaTalk ^{ng} 5-way connector	Used to branch, split, or make additional connections in SeaTalk or SeaTalk ^{ng} networks.
Blanking plug	Inserted into unused spur connector positions in a 5-way connector or T-piece.

10.3 SeaTalk^{ng}® cables and accessories

SeaTalk^{ng} cables and accessories for use with compatible products.

Part No	Description	Notes
T70134	SeaTalk ^{ng} starter kit	Includes: <ul style="list-style-type: none"> • 1 x 5 Way connector (A06064) • 2 x Backbone terminator (A06031) • 1 x 3 m (9.8 ft) spur cable (A06040) • 1 x Power cable (A06049)
A25062	SeaTalk ^{ng} Backbone Kit	Includes: <ul style="list-style-type: none"> • 2 x 5 m (16.4 ft) Backbone cable (A06036) • 1 x 20 m (65.6 ft) Backbone cable (A06037) • 4 x T-piece (A06028) • 2 x Backbone terminator (A06031) • 1 x Power cable (A06049)
A06038	SeaTalk ^{ng} 0.4 m (1.3 ft) spur	
A06039	SeaTalk ^{ng} 1 m (3.3 ft) spur	
A06040	SeaTalk ^{ng} 3 m (9.8 ft) spur	
A06041	SeaTalk ^{ng} 5 m (16.4 ft) spur	
A06042	SeaTalk ^{ng} 0.4 m (1.3 ft) elbow spur	
A06033	SeaTalk ^{ng} 0.4 m (1.3 ft) backbone	
A06034	SeaTalk ^{ng} 1 m (3.3 ft) backbone	
A06035	SeaTalk ^{ng} 3 m (9.8 ft) backbone	
A06036	SeaTalk ^{ng} 5 m (16.4 ft) backbone	
A06068	SeaTalk ^{ng} 9 m (29.5 ft) backbone	
A06037	SeaTalk ^{ng} 20 m (65.6 ft) backbone	

Part No	Description	Notes
A06043	SeaTalk ^{ng} to bare ends 1 m (3.3 ft) spur	
A06044	SeaTalk ^{ng} to bare ends 3 m (9.8 ft) spur	
A06049	SeaTalk ^{ng} Power cable	
A06031	SeaTalk ^{ng} Terminator	
A06028	SeaTalk ^{ng} T-piece	Provides 1 x spur connection
A06064	SeaTalk ^{ng} 5-way connector	Provides 3 x spur connections
A06030	SeaTalk ^{ng} backbone extender	
E22158	SeaTalk to SeaTalk ^{ng} converter kit	Allows the connection of SeaTalk devices to a SeaTalk ^{ng} system.
A80001	SeaTalk ^{ng} Inline terminator	Provides direct connection of a spur cable to the end of a backbone cable. No T-piece required.
A06032	SeaTalk ^{ng} Blanking plug	
R12112	ACU / SPX SeaTalk ^{ng} spur cable 0.3 m (1.0 ft)	Connects an SPX course computer or an ACU to a SeaTalk ^{ng} backbone.
A06047	SeaTalk (3 pin) to SeaTalk ^{ng} adaptor cable 0.4 m (1.3 ft)	
A22164	SeaTalk to SeaTalk ^{ng} spur 1 m (3.3 ft) spur	
A06048	SeaTalk2 (5 pin) to SeaTalk ^{ng} adaptor cable 0.4 m (1.3 ft)	
A06045	DeviceNet adaptor cable (Female)	Allows the connection of NMEA 2000 devices to a SeaTalk ^{ng} system.
A06046	DeviceNet adaptor cable (Male)	Allows the connection of NMEA 2000 devices to a SeaTalk ^{ng} system.
E05026	DeviceNet adaptor cable (Female) to bare ends.	Allows the connection of NMEA 2000 devices to a SeaTalk ^{ng} system.
E05027	DeviceNet adaptor cable (Male) to bare ends.	Allows the connection of NMEA 2000 devices to a SeaTalk ^{ng} system.

Appendix A NMEA 2000 PGN support

The unit supports the following NMEA 2000 PGNs.

PGN	Description	Transmit (Tx)	Receive (Rx)
59904	ISO Request		•
59932	ISO Acknowledgement	•	
60160	ISO Transport protocol, data transfer		•
60416	ISO Transport protocol	•	•
60928	ISO Address claim	•	•
65240	ISO Commanded address		•
126208	NMEA - Request group function		•
126208	NMEA - Command group function		•
126208	NMEA - Acknowledge group function	•	
126464	Transmission PGN List	•	
126464	Received PGN List	•	
126992	System time	•	
126993	Heartbeat	•	
126996	Product information	•	
126998	Configuration information	•	
129025	Position, rapid update	•	
129026	COG & SOG rapid update	•	
129027	Position delta high precision	•	
129029	GNSS Position data	•	
129033	Time and date	•	
129044	Datum	•	•
129540	GNSS Satellites in view	•	
129542	GNSS Pseudo range noise statistics	•	

Index

A			
Accessories	46		
B			
Backbone length, SeaTalkng®	19		
Battery connection.....	20		
Box contents, <i>See</i> Parts supplied			
Bracket mounting.....	26		
C			
Cable bend radius	18		
Cable connection, <i>See</i> Connecting cables			
Cable connector, <i>See</i> Connecting cables			
Cable protection	18		
Cable routing	18		
Circuit breaker connection.....	20		
Cleaning	7, 37		
Compass safe distance	15		
Connecting cables.....	18		
Contact details.....	40		
D			
Deck mounting kit.....	25–27		
Dis-assembly, Mounting adaptor	28		
Distribution panel connection	20		
E			
Electromagnetic Compatibility	15		
EMC, <i>See</i> Electromagnetic Compatibility			
F			
Fuse rating, SeaTalkng®.....	19		
G			
GPS fix status.....	31		
GPS Set-up	30		
GPS Status.....	30		
I			
Installation	24–27		
Installation equipment, <i>See</i> Tools			
Interference	15		
<i>See also</i> Compass safe distance			
L			
LEN, <i>See</i> Load Equivalency Number			
Load equivalency number	19		
Locking collar.....	18		
M			
Maintenance.....	7, 36		
		Maximum system loading, SeaTalkng®	19
N			
Network length, SeaTalkng®, <i>See</i> Backbone length, SeaTalkng®			
P			
Pack contents, <i>See</i> Parts supplied			
Parts supplied.....	12		
Pole mounting.....	24		
Power connection point	19		
Power supply, <i>See</i> SeaTalkng power supply			
Product dimensions, <i>See</i> Dimensions			
Product loading, <i>See</i> Load Equivalency Number			
Product support	40		
R			
Radio Frequency (RF) interference	14		
Rail mounting.....	24		
Release, unit.....	28		
Riser	27		
Routine checks	36		
S			
SeaTalkng.....	10		
Securing cables	18		
Service Center.....	40		
Servicing.....	7, 36		
Software updates.....	13		
Strain relief, <i>See</i> Cable protection			
Surface mounting	24–25, 27		
T			
Technical support.....	40		
Thermal breaker rating, SeaTalkng®.....	19		
Tools	13		
Troubleshooting	32		
GNSS.....	33		
U			
Upgrading, <i>See</i> Software updates			
W			
Wall Bracket	26		
Warranty	40		

Raymarine[®]
BY  **FLIR**[®]



www.raymarine.com

