

# REMOTE Battery Bank Status Monitor

## ► Installation Instructions

Battery Status Monitor Wiring Diagram

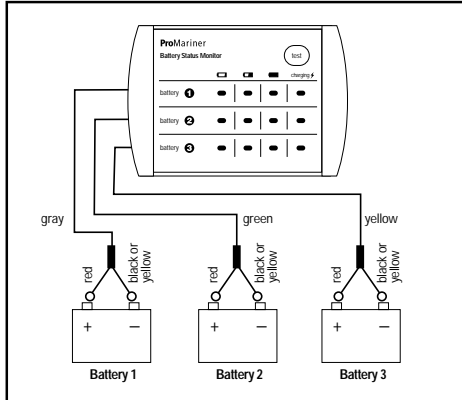

No.1 Surface Mount Installation

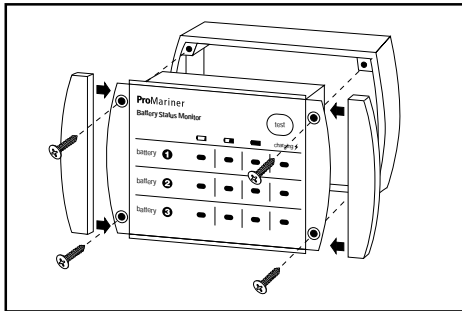

No. 2 Flush Mount Installation

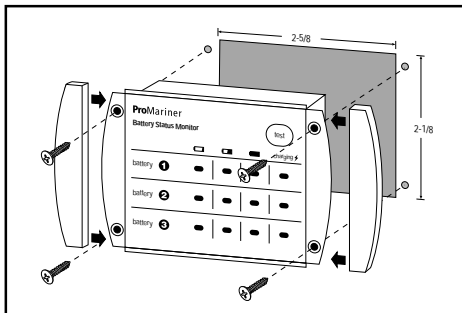

**Step 1:** Make sure engine and battery charger is off. Open battery and engine compartment and ventilate at least 15 minutes prior to installation. Observe all battery manufacturer's safety precautions.

**Step 2:** Locate display in a visible location that allows for access to the "Push-to-Test" button. (recommended console/helm)

**Step 3:** Use drill template to mark (4) mounting holes and (2) cable thru holes. See illustration No. 1 for surface mount application.

- or -

Use drill template to mark and cut a 2-5/8" x 2-1/8" opening and (4) mounting holes. See illustration No. 2 for flush mount application.

*Note: Use caution prior to drilling or cutting to ensure proper clearance from existing wiring and hardware.*

**Step 4:** Assemble remote monitor panel without snap on mounting covers. Place cable in thru holes, align mounting holes and using a hand screwdriver install the 4 stainless steel screws provided. Snap on mounting ear covers to complete installation.

**Step 5:** Run each of the remote monitor battery cables, free from sharp objects, to each appropriate battery compartment.

**Step 6:** Attach remote monitor battery cable as shown in the wiring diagram. (observe proper polarity colors and connections)

**Step 7:** To use the remote status monitor, the onboard battery charger and engine must be turned off. With the AC power removed from the charger and the engine off, simply push the highly visible (yellow) "Push-to-Test" button located on the front of the remote status monitor. While holding the "Push-to-Test" button view the relative charge status of each of the batteries connected.

Each battery bank has 3 (green) LED indicators to indicate the following:

- Battery is discharged
- Battery is at 50% charge
- Battery is fully charged

Drill Template

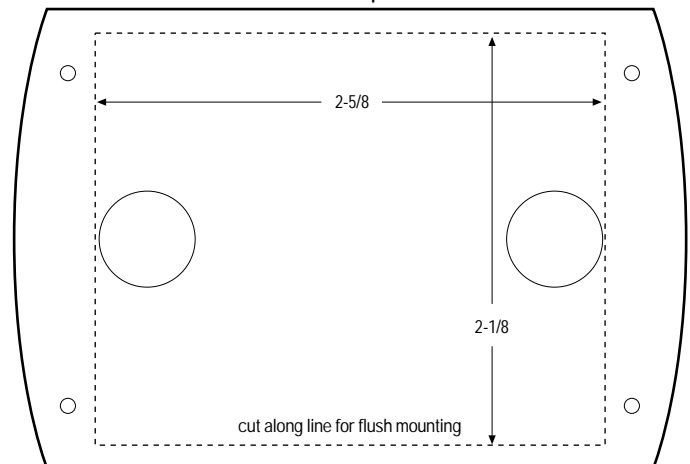

Professional Mariner, LLC

PO. Box 968  
Rye, New Hampshire 03870  
TEL: 603-433-4440  
FAX: 603-433-4442  
www.pmariner.com

made in Taiwan